



Ethernet & 4-20 mA Output Transmitter for Dual Channel Pulse Totalizer Input



Features

- Ethernet Serial Data I/O, Modbus TCP or Laurel ASCII protocol
- 4-20 mA or 0-10V transmitter output, 16 bits, jumper selectable, isolated
- Dual 120 mA solid state relays for alarm or control, isolated
- 5V, 10V, 12V or 24V dc transducer excitation output, isolated
- Two independently field-scalable pulse input channels
- Up counting from zero to preset value using positive scale factor
- Down counting from preset to zero using negative scale factor
- Inputs from NPN or PNP proximity switches, contact closures, digital logic, or magnetic pickups down to 12 mV, pulse rates to 1 MHz
- Digital span adjust from 0 to $\pm 99,999$, zero adjust from -99,999 to +99,999
- Universal 85-264 Vac / 90-300 Vdc or 10-48 Vdc / 12-32 Vac power
- Power over Ethernet (PoE) jumper selectable with 10-48 Vdc supply

Description

The Laureate pulse input totalizer transmitter accepts two independently scalable input channels from a wide range of pulse sources, such as NPN or PNP proximity switches, contact closures, digital logic, magnetic pickups down to 12 mV, or AC voltages to 250 Vac. Input pulse rates can be as high as 1 MHz.

With a Standard Main Board, the transmitter output can be scaled to track total (such as gallons) or rate (such as gallons per minute). Square root extraction is standard.

With an Extended Main Board, the transmitter can also:

- **Count up to a preset or down from a preset to zero.** Such applications typically utilize the transmitter's two solid state relays, which are standard. External reset of totals is via a special three-position screw terminal connector.
- **Perform custom-curve linearization** on rate or total, for example to extend the range of transducers. Exceptionally accurate custom-curve linearization is provided by a curvilinear spline fit with up to 180 data points.
- **Combine channels A and B arithmetically** so that the transmitter output tracks A+B (e.g., sum of two flows or totals), A-B (e.g., difference of two flows or totals), AxB (e.g., horsepower as product of force and RPM), A/B (ratio of two flow or totals), and A/B-1 (draw or relative elongation of material between rollers).

The dual-channel signal conditioner used for pulse detection accepts inputs from proximity switches with PNP or NPN output, TTL or CMOS logic, magnetic pickups, contact closures, and other signals from 12 mV to 250 Vac. Jumper selections provide optimum operation for different sensor types and noise conditions. A built-in 5V, 10V or 24V dc excitation supply can power proximity switches and other sensors, and eliminate the need for an external power supply.

Standard features of Laureate LTE transmitters include:

- **Ethernet I/O, isolated.** Supported protocols are Modbus RTU and ASCII (tunneled via Modbus TCP) and Laurel ASCII. The latter is simpler than the Modbus protocol and is recommended when all devices are Laureates. Note that RS232 or RS485 data I/O in lieu of Ethernet is provided by our LT Series transmitters.
- **4-20 mA, 0-20 mA or 0-10V analog transmitter output,** isolated, jumper-selectable and user scalable. All selections provide 16-bit (0.0015%) resolution of output span and 0.02% output accuracy of a reading from -99,999 to +99,999 counts that is also transmitted digitally. Output isolation from signal and power grounds eliminates potential ground loop problems. The supply can drive 20 mA into a 500 ohm (or lower) load for 10V compliance, or 10V into a 5K ohm (or higher) load for 2 mA compliance.
- **Dual solid state relays,** isolated. Available for local alarm or control. Rated 120 mA at 130 Vac or 180 Vdc.
- **Transducer excitation output,** isolated. User selectable 5V@100 mA, 10V@120 mA, 12V@140 mA or 24V@50 mA.
- **Universal 85-264 Vac power.** Low-voltage 10-48 Vdc or 12-32 Vac power is optional.

Discovery and configuration of Laureate Ethernet Nodes is easily achieved with Laurel's Node Manager Software, and the discovered transmitters can then be programmed using Laurel's Instrument Setup Software. Both softwares run on a PC under MS Windows and can be downloaded at no charge.



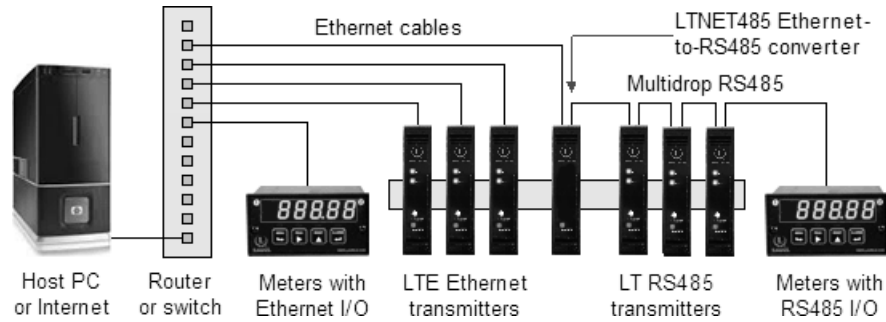

Specifications

Pulse Input	
Signal Types	AC, pulses from NPN, PNP transistors, contact closures, magnetic pickups.
Grounding	Common ground for channels A & B
Channel A Frequency	0.005 Hz to 1 MHz
Channel B Frequency	0.005 Hz to 250 kHz
Minimum Signal	Nine ranges from (-12 to +12 mV) to (+1.25 to +2.1V)
Maximum Signal	250 Vac
Noise Filter	1 MHz, 30 kHz, 250 Hz (selectable)
Contact Debounce	0, 3, 50 ms (selectable)
Analog Output (standard)	
Output Levels	4-20 mA and 0-10 Vdc (selectable)
Compliance, 4-20 mA	10V (0-500Ω load)
Compliance, 0-10V	2 mA (5 kΩ load)
Output Resolution	16 bits (65,536 steps)
Output Accuracy	0.02% of output span
Output Update Rate	Programmed gate time + 30 ms + 0-2 signal periods
Output Isolation	250V rms working, 2.3 kV rms per 1 minute test
Sensor Excitation Output (standard)	
Output Levels	5V@100 mA, 10V@120 mA, 12V@140 mA, 24V@50 mA (jumper selectable)
Output Isolation	50V from signal ground
Dual Relay Output (standard)	
Relay Type	Two solid state relays, SPST, normally open, Form A
Load Rating	120 mA at 140 Vac or 180 Vdc
Serial Communications (standard)	
Type	10/100Base-T Ethernet per IEEE 802.3
Data Rates	300, 600, 1200, 2400, 4800, 9600, 19200 baud
Output Isolation	250V rms working, 2.3 kV rms per 1 min test
Serial Protocols	Modbus TCP, Modbus RTU, Modbus ASCII, Laurel ASCII
Modbus Compliance	Modbus over Serial Line Specification V1.0 (2002)
Digital Addresses	247 for Modbus, 31 for Laurel ASCII
Power Input	
Standard Power	85-264 Vac or 90-300 Vdc
Low Power Option	10-48 Vdc or 12-32 Vac
Power Frequency	DC or 47-63 Hz
Power Isolation	250V rms working, 2.3 kV rms per 1 min test
Power Consumption	2W typical, 3W with max excitation output
Mechanical	
Dimensions	129 x 104 x 22.5 mm case
Mounting	35 mm rail per DIN EN 50022
Electrical Connections	Plug-in screw-clamp connectors



Environmental	
Operating Temperature	-40°C to 70°C
Storage Temperature	-40°C to 85°C
Relative Humidity	95% at 40°C, non-ondensing
Cooling Required	Mount transmitters with ventilation holes at top and bottom. Leave 6 mm (1/4") between transmitters, or force air with a fan.

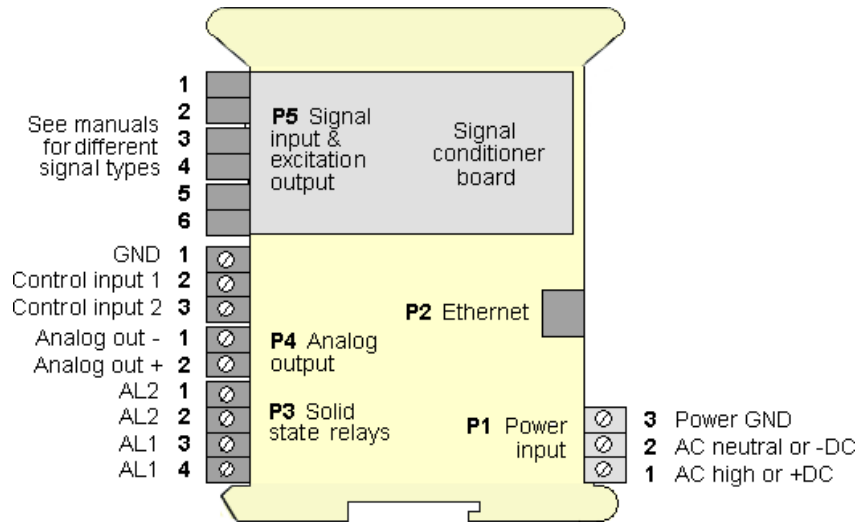

Pinout

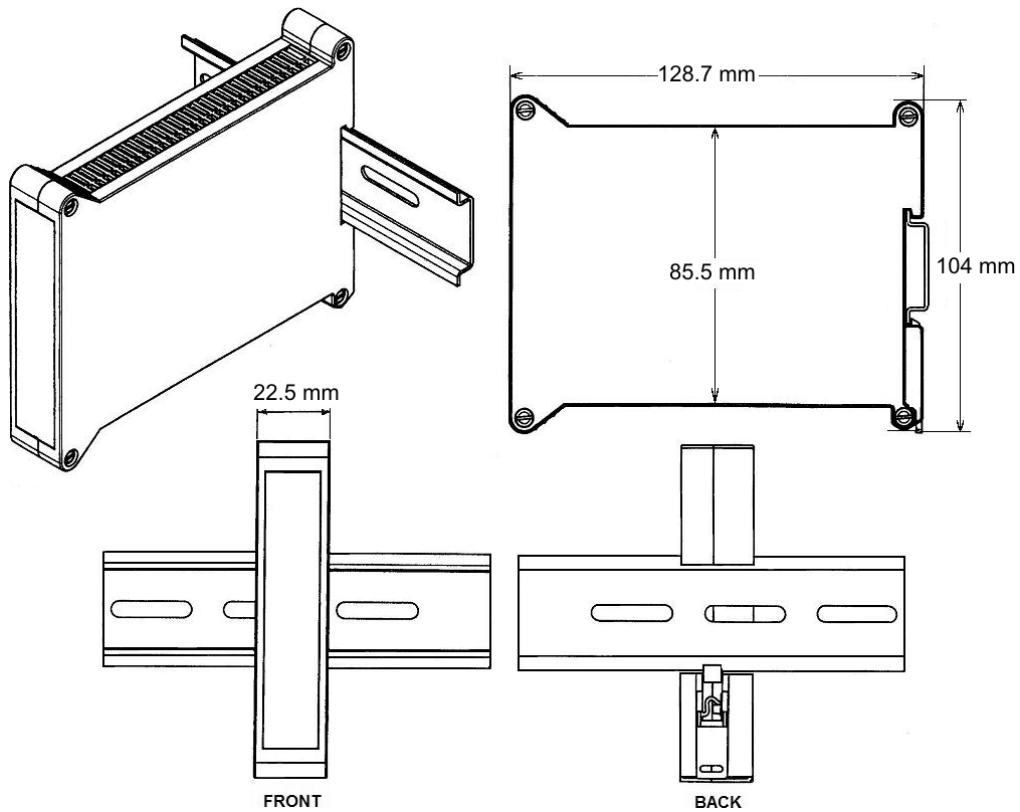

Mechanical

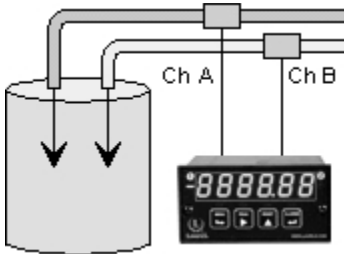
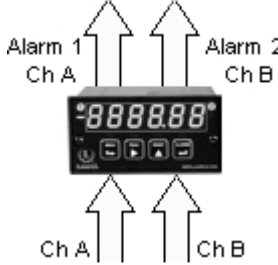

Application Examples of Totalizing Meters and Transmitters

Combining Two Totals	
	<p>A+B, A-B, A/B and AxB arithmetic functions are available with the Extended totalizing transmitter. A+B can sum two totals, while A-B subtracts the outflow total from inflow total. A/B ratio applied to two totals helps assure the proper mixing of components.</p>
Up or Down Counting with Preset	
	<p>A single Laureate dual-channel totalizing transmitter will handle two repetitive fill operations by counting from zero up to a preset, or down from a preset to zero. The dual relay option is required.</p>
Machine ON Time and Utilization	
	<p>An easy way to measure the ON time of machines is to count AC line cycles and scale the total to hours. To display machine utilization or duty cycle in percent, use the Extended totalizing transmitter. Connect Channel A to switched AC and Channel B to the AC line, and apply a 100 multiplier to the A/B ratio.</p>
Custom Curve Linearization	
	<p>The Extended version of the Laureate dual channel totalizing transmitter can transmit scaled rate or total for the same channel at the push of a button, and alarm both the rate and total. The Extended version can also do curve linearization, thereby extending the working range and accuracy of flow transducers.</p>

Ordering Guide

Create a model a model number in this format: **LTE60FR**

Transmitter Type	LTE Laureate Ethernet & 4-20 mA Transmitter
Main Board	<p>6 Standard Main Board 8 Extended Main Board</p> <p><i>With Standard Main Board:</i> Scalable to $\pm 999,999$ for frequency, rate, square root of rate, up or down total, period, A-to-B time interval. <i>With Extended Main Board:</i> Above, plus rate and total simultaneously, ratio (A/B), draw (A/B-1), other arithmetic functions (AxB, A+B, A-B), phase angle, stopwatch, up/down counting, batching operation, linearization of nonlinear inputs.</p>
Power	<p>0 Isolated 85-264 Vac or 90-300 Vdc 1 Isolated 12-32 Vac or 10-48 Vdc</p>
Input Type	FR Dual-Channel Frequency

