



Features

- Attractive benchtop housing
- Available with one or two front panel 1/8 DIN cutouts
- Suitable for Laureate digital panel meters, counters, timers and remote displays
- Suitable for 1/8 DIN size instruments by other manufacturers
- Attractive, no-maintenance, black ABS polycarbonate material
- Cooling slits in top and bottom surfaces
- Easy to machine front and rear panels
- Back panel with computer-style C14 AC power inlet and AC power switch.

Description

Designed for benchtop and laboratory use, these enclosures provide an alternative to panel mounting of meters when an instrument panel is not available. They provide a finished instrument look to what would otherwise be isolated meters on a work bench or shelf. They are economically priced, provide an attractive professional look, and improve electrical safety.

Two versions are available. Model CASE1 provides a single 1/8 DIN 45 x 92 mm front panel cutout, which is set to one side to leave unobstructed front panel space for user furnished indicator lights, knobs and switches. Model CASE2 provides two 1/8 DIN front panel cutouts, for example to display voltage and current on two separate meters.

The rear of the case provides an AC power inlet and a double-pole toggle switch. An AC power cord of the type used with computers, electrical feedthroughs, and internal wiring are left to the user. In lieu of electrical feedthroughs, a small rectangular opening can be cut at the bottom edge of the rear panel to bring external wires directly to the meter(s). The case can also be used without a rear panel, since the black open interior of the case is virtually indistinguishable from the black rear panel.

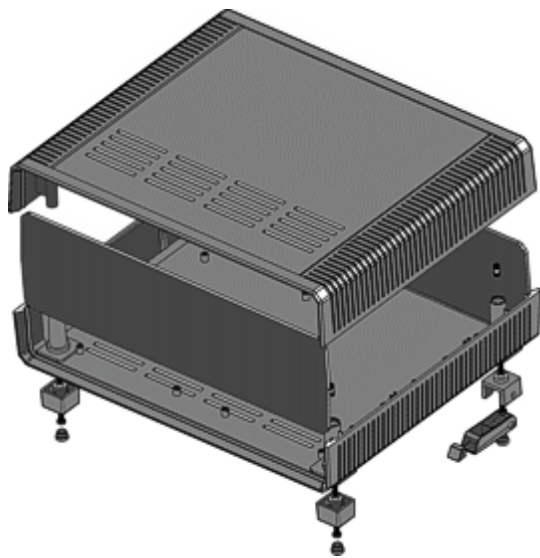

Benchtop case construction

Construction is simple and rugged. Four screws hold together top and bottom clamshell halves, which provide wrap-round grooves to secure identically sized front and rear panels. The same screws are also used to attach two fixed rear mounting feet and two front feet which, which can fold out to tilt the case by 9° at the option of the user. The case material is black polycarbonate plastic, which is maintenance free and is easy to drill or saw. Vent slits in the top and bottom surfaces allow air circulation for cooling.

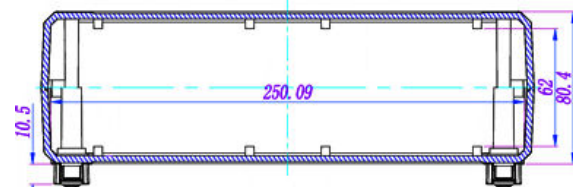
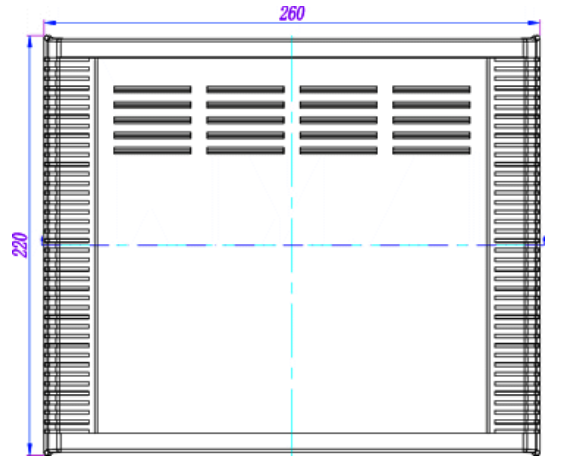

Benchtop case dimensions, mm



Specifications

Dimensions	
External, main body	80.4 x 260 x 220 mm (3.17" x 10.24" x 8.66"), H x W x D
Internal space	69 x 253 x 199 mm (2.72" x 9.96" x 7.83"), H x W x D
Depth behind Laureate meter	85 mm (3.35")
Front panel cutouts	One 45 x 92 mm (1/8 DIN), Model CASE1 Two 45 x 82 mm (1/8 DIN), Model CASE2
Rear panel cutout	One 27.5 x 38 mm for power inlet & power switch assembly
Construction	
Material	ABS polycarbonate, black.
Main components	Clamshell top and bottom halves, front and rear panels set in grooves.
Gaskets	2.4 mm (0.095"), front and rear panels.
Panel thickness	Two fold-out legs to raise front of case by 32 mm (1.26") to 9°.
Tilt Provision	Cooling Provision Air slits in top and bottom of case.
Electrical connection	IEC320 C14 three-prong AC power inlet for 120 or 240 Vac power cord
Power switch	Rocker switch, 120/240 Vac, double-pole (not wired).

Assembly

1. Install meter(s) in 1/8 DIN cutout(s) of front panel.
2. Install any other components in front panel.
3. Orient rear panel so that cutout for power inlet is at bottom left or bottom right of case.
4. Make opening(s) in rear panel for signal wiring. These can be drilled holes or a rectangular cutout at bottom edge. Or simply use case without a rear panel by wiring directly to meter(s).
5. Press power inlet into rear panel so that switch opening is toward outer edge of case for easy access to switch.
6. Press switch into power inlet. Orient switch so that the "I" symbol, which indicates "closed," is toward top.
7. Install any other components in rear panel.
8. Make electrical wiring inside case and test electrically.
9. Orient bottom clamshell half so that air circulation slits are toward rear, insert front and rear panels, and place top clamshell half so that air circulation slits are toward rear.
10. Using provided screws and a narrow shank Phillips screwdriver, attach two fixed rear feet and two folding front feet. The same screws hold clamshell halves together. Orient front feet so that they fold toward rear.
11. Insert rubber pads over screw openings in feet, thereby completing assembly.

Ordering Guide

CASE1	Bench Style Case with Single 1/8 DIN Front Panel Cutout
CASE2	Bench Style Case with Dual 1/8 DIN Front Panel Cutouts