



Features

- 4-20 mA, 0-20 mA, 0-10V or -10V to +10V transmitter output, 16 bits, isolated
- RS232 or RS485 serial data output, Modbus or Laurel ASCII protocol, isolated
- Dual 120 mA solid state relays for alarm or control, isolated
- Five precalibrated resistance input ranges from 20.000 Ω to 200.00 k Ω
- Optional fixed 2 M Ω input range
- 1 m Ω resolution on 20 Ω scale
- Custom curve linearization for changing resistance transducers
- 2, 3 or 4-wire connection with lead resistance compensation
- Analog output resolution 0.0015% of span (16 bits), accuracy $\pm 0.02\%$ of span
- DIN rail mount housing only 22.5 mm wide, detachable screw-clamp connectors
- Universal 85-264 Vac / 90-300 Vdc or 10-48 Vdc / 12-32 Vac power



Description

The **Laureate Resistance Transmitter** is factory calibrated for five jumper selectable resistance ranges from 20 Ω to 200 k Ω . Accuracy is an exceptional 0.01% of full scale ± 2 counts. Resolution is one part in 20,000. In the 20 Ω range, resolution is 1 m Ω , making the transmitter suitable for contact resistance and conductance measurements.

Transmitter connections can be via 2, 3 or 4 wires. With 4-wire hookup, 2 wires are used for excitation and two separate wires are used to sense the voltage across the resistance to be measured, thereby eliminating any lead resistance effects. With 3-wire hookup, the transmitter senses the combined voltage drop across the RTD plus two excitation leads. It also senses the voltage drop across one excitation lead, and then subtracts twice this voltage from the combined total. This technique effectively subtracts the lead resistance if the excitation leads are the same.

All resistance ranges are digitally calibrated at the factory, with calibration factors stored in EEPROM on the signal conditioner board. This allows ranges and signal conditioner boards to be changed in the field without recalibrating the transmitter. If desired, the transmitter can easily be calibrated using external standards plus scale and offset in software.

Fast read rate at up to 50 or 60 conversions per second while integrating the signal over a full power line cycle is provided by Concurrent Slope (Pat 5,262,780) analog-to-digital conversion. High read rate is ideal for peak or valley capture and for real-time computer interface and control.

Open sensor indication is standard and may be set up to indicate either upscale or downscale. Excitation is provided by the transmitter.

Custom curve linearization, available with the Extended version, makes this transmitter ideal for use with transducers whose output is a changing resistance.

Standard features of Laureate transmitters include:

- **4-20 mA, 0-10V or -10V to +10V analog transmitter output**, isolated, jumper-selectable and user scalable. All selections provide 16-bit (0.0015%) resolution of output span and 0.02% output accuracy of a reading from -99,999 to +99,999 counts that is also transmitted digitally. Output isolation from signal and power grounds eliminates potential ground loop problems.
- **Serial communications output**, isolated. User selectable RS232 or RS485, half or full duplex. Three protocols are user selectable: Modbus RTU, Modbus ASCII, or Laurel ASCII. Modbus operation is fully compliant with Modbus Over Serial Line Specification V1.0 (2002). The Laurel ASCII protocol allows up to 31 Laureate devices to be addressed on the same RS485 data line. It is simpler than the Modbus protocol and is recommended when all devices are Laureates.
- **Dual solid state relays**, isolated. Available for local alarm or control. Rated 120 mA at 130 Vac or 170 Vdc.
- **Universal 85-264 Vac power**. Low-voltage 10-48 Vdc or 12-32 Vac power is optional.

Easy Transmitter programming is via Laurel's Instrument Setup Software, which runs on a PC under MS Windows. This software can be downloaded from this website at no charge. The required transmitter-to-PC interface cable is available from Laurel (P/N CBL04).

Specifications

Range	Resolution	Accuracy	Excitation Current
0-2.0000 Ω	0.1 mΩ	±0.01% of range ± 2 counts	5 mA
0-20.000 Ω	1 mΩ		5 mA
0-200.00 Ω	10 mΩ		500 μA
0-2000.0 Ω	100 mΩ		50 μA
0-20000 Ω	1 Ω		5 μA
0-200.00 kΩ	10 Ω		500 nA
0-2.0000 MΩ	100 Ω		500 nA
Signal Input			
Input Resolution	16 bits (65,536 steps)		
Input Accuracy	±0.01% of full scale ± 2 counts		
Update Rate, Max	50/sec at 50 Hz, 60/sec at 60 Hz		
Analog Output (standard)			
Output Levels	4-20 mA, 0-20 mA, 0-10 Vdc, -10 to +10Vdc (user selectable)		
Compliance at 20 mA	10V (0-500Ω load)		
Compliance at 10V	2 mA (5 kΩ load or higher)		
Output Resolution	16 bits (65,536 steps)		
Output Accuracy	0.02% of output span plus conversion accuracy		
Output Isolation	250V rms working, 2.3 kV rms per 1 minute test		
Serial Communications (standard)			
Signal Types	RS232 or RS485 (half or full duplex)		
Data Rates	300, 600, 1200, 2400, 4800, 9600, 19200 baud		
Output Isolation	250V rms working, 2.3 kV rms per 1 min test		
Serial Protocols	Modbus RTU, Modbus ASCII, Laurel ASCII		
Modbus Modes	RTU or ASCII		
Modbus Compliance	Modbus over Serial Line Specification V1.0 (2002)		
Digital Addressing	247 Modbus addresses. Up to 32 devices on an RS485 line w/o a repeater.		
Dual Relay Output (standard)			
Relay Type	Two solid state relays, SPST, normally open, Form A		
Load Rating	120 mA at 140 Vac or 180 Vdc		
Power Input			
Standard Power	85-264 Vac or 90-300 Vdc		
Low Power Option	10-48 Vdc or 12-32 Vac		
Power Frequency	DC or 47-63 Hz		
Power Isolation	250V rms working, 2.3 kV rms per 1 min test		
Power Consumption	2W typical, 3W with max excitation output		
Mechanical			
Dimensions	129 x 104 x 22.5 mm case		
Mounting	35 mm rail per DIN EN 50022		
Electrical Connections	Plug-in screw-clamp connectors		
Environmental			
Operating Temperature	0°C to 55°C		
Storage Temperature	-40°C to 85°C		
Relative Humidity	95% at 40°C, non-condensing		
Cooling Required	Mount transmitters with ventilation holes at top and bottom. Leave 6 mm (1/4") between transmitters, or force air with a fan.		

Pinout

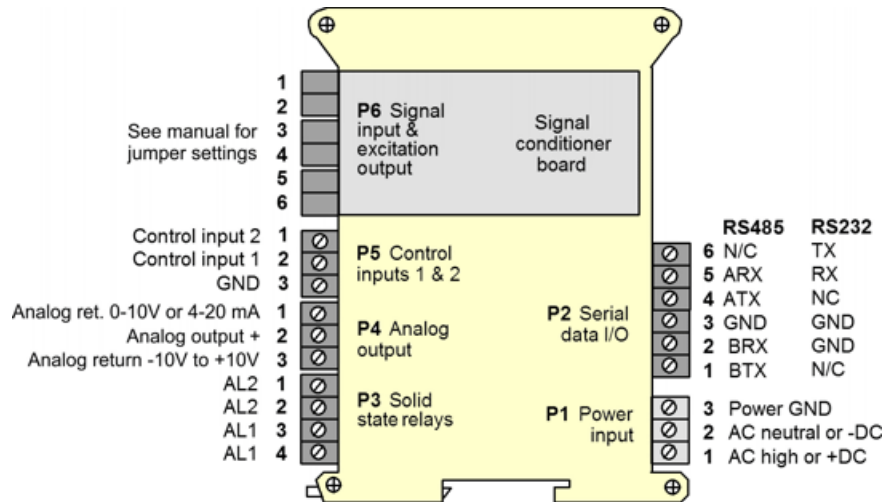

Mechanical

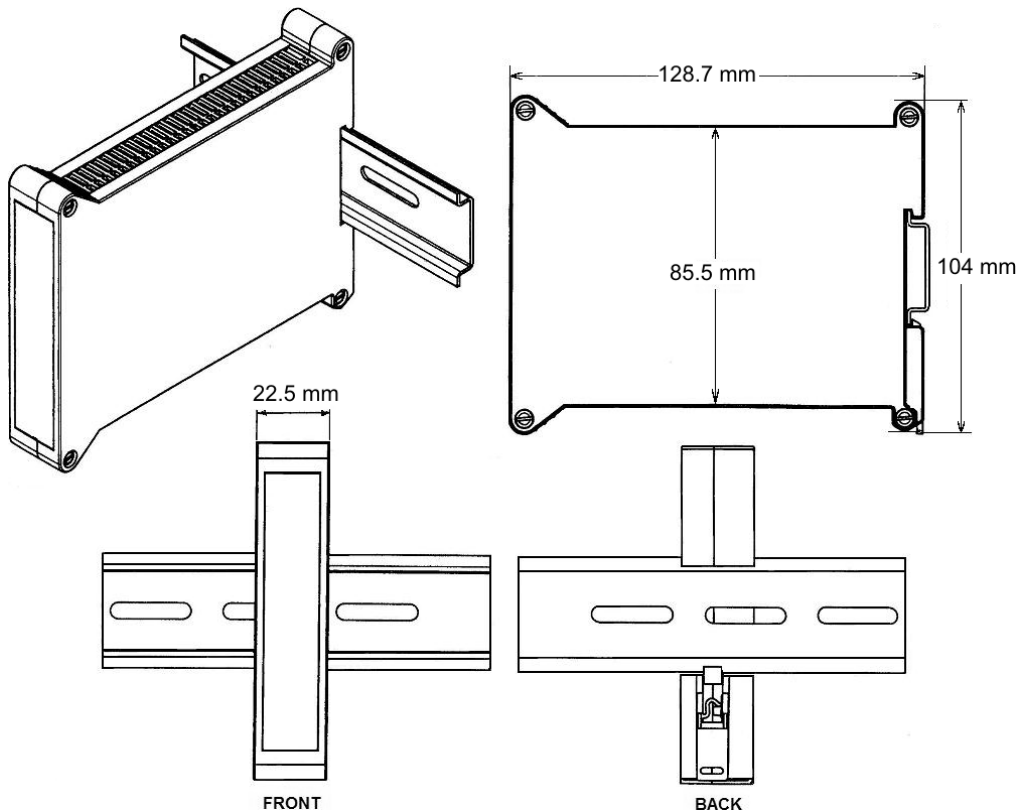

QA Application with Relays in Passband Mode

A deviation limit (50 mΩ in this example) is set up around both sides of a setpoint. The relay closes (or opens) when the reading falls within the deviation band, and opens (or closes) when the reading falls outside of this band. This mode sets up a passband around the setpoint and can be used for contact resistance testing in a production environment.

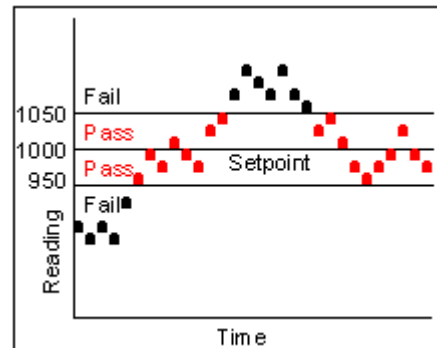

RTD Hookup

4-wire Resistance

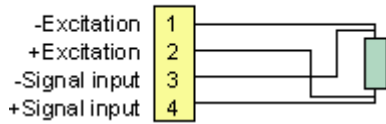

In **4-wire hookup**, different pairs of leads are used to apply the excitation current and sense the voltage drop across the unknown resistance, so that the IR drop across the excitation leads is not a factor.

3-wire Resistance

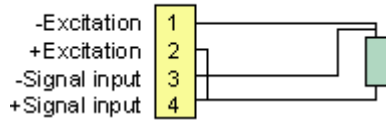

In **3-wire hookup**, the transmitter senses the combined voltage drop across the unknown resistance plus two excitation leads. It also senses the voltage drop across one excitation lead, and then subtracts twice this voltage from the combined total. This technique effectively subtracts all lead resistance and compensates for ambient temperature changes if the two excitation leads are identical.

2-wire Resistance

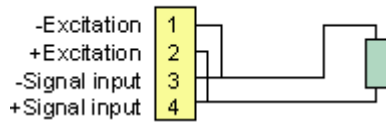

In **2-wire hookup**, the transmitter senses the combined voltage drop across the unknown resistance and both lead wires. The voltage drop across the lead wires can be measured by shorting out the resistance during transmitter setup, and this voltage is then automatically subtracted from the combined total. However, changing resistance of the lead wires due to ambient temperature changes will not be compensated.

Ordering Guide

Create a model a model number in this format: **LT20R1**

Transmitter Type	LT Laureate 4-20 mA & RS232/RS485 output transmitter
Main Board	2 Standard Main Board
Power	0 Isolated 85-264 Vac or 90-300 Vdc 1 Isolated 10-48 Vdc or 12-32 Vac
Resistance Range	R0 0-20 ohms (factory special fixed range) R1 0-20 ohms R2 0-200 ohms R3 0-2 kohms R4 0-20 kohms R5 0-200 kohms R6 0-2 Mohms (factory special fixed range) Note: The same signal conditioner board can be used for resistance and RTD temperature measurement.
Accessories	CBL04 RS232 cable, 7ft. Connects RS232 screw terminals of LT transmitter to DB9 port of PC. CBL02 USB to RS232 adapter cable. Combination of CBL02 and CBL04 connects transmitter RS232 terminals to PC USB port.