



Features

- 4-20 mA, 0-20 mA, 0-10V or -10V to +10V transmitter output, 16 bits, isolated
- RS232 or RS485 serial data output, Modbus or Laurel ASCII protocol, isolated
- Dual 120 mA solid state relays for alarm or control, isolated
- Two independently field-scalable pulse input channels
- Up counting from zero to preset value using positive scale factor
- Down counting from preset to zero using negative scale factor
- Inputs from NPN or PNP proximity switches, contact closures, digital logic, or magnetic pickups down to 12 mV, pulse rates to 1 MHz
- Analog output resolution 0.0015% of span (16 bits), accuracy $\pm 0.02\%$ of span
- 5V, 10V or 24V dc transducer excitation output, isolated
- Universal 85-264 Vac / 90-300 Vdc or 10-48 Vdc / 12-32 Vac power



Description

The Laureate pulse input totalizer transmitter accepts two independently scalable input channels from a wide range of pulse sources, such as NPN or PNP proximity switches, contact closures, digital logic, magnetic pickups down to 12 mV, or AC voltages to 250 Vac. Input pulse rates can be as high as 1 MHz.

With a Standard Main Board, the transmitter output can be scaled to track total (such as gallons) or rate (such as gallons per minute). Square root extraction is standard.

With an Extended Main Board, the transmitter can also:

- **Count up to a preset or down from a preset to zero.** Such applications typically utilize the transmitter's two solid state relays, which are standard. External reset of totals is via a special three-position screw terminal connector.
- **Perform custom-curve linearization** on rate or total, for example to extend the range of transducers. Exceptionally accurate custom-curve linearization is provided by a curvilinear spline fit with up to 180 data points.
- **Combine channels A and B arithmetically** so that the transmitter output tracks A+B (e.g., sum of two flows or totals), A-B (e.g., difference of two flows or totals), AxB (e.g., horsepower as product of force and RPM), A/B (ratio of two flow or totals), and A/B-1 (draw or relative elongation of material between rollers).

The dual-channel signal conditioner used for pulse detection accepts inputs from proximity switches with PNP or NPN output, TTL or CMOS logic, magnetic pickups, contact closures, and other signals from 12 mV to 250 Vac. Jumper selections provide optimum operation for different sensor types and noise conditions. A built-in 5V, 10V or 24V dc excitation supply can power proximity switches and other sensors, and eliminate the need for an external power supply.

Standard features of Laureate transmitters include:

- **4-20 mA, 0-10V or -10V to +10V analog transmitter output**, isolated, jumper-selectable and user scalable. All selections provide 16-bit (0.0015%) resolution of output span and 0.02% output accuracy of a reading from -99,999 to +99,999 counts that is also transmitted digitally. Output isolation from signal and power grounds eliminates potential ground loops.
- **Serial communications output**, isolated. User selectable RS232 or RS485, half or full duplex. Three protocols are user selectable: Modbus RTU, Modbus ASCII, or Laurel ASCII. Modbus operation is fully compliant with Modbus Over Serial Line Specification V1.0 (2002). The Laurel ASCII protocol allows up to 31 Laureate devices to be addressed on the same RS485 data line. It is simpler than the Modbus protocol and is recommended when all devices are Laureates.
- **Dual solid state relays**, isolated. Available for local alarm or control. Rated 120 mA at 130 Vac or 170 Vdc.
- **Transducer excitation output**, isolated. User selectable 5V@100 mA, 10V@120 mA or 24V@50 mA.
- **Universal 85-264 Vac power.** Low-voltage 10-48 Vdc or 12-32 Vac power is optional.

Easy Transmitter programming is via Laurel's Instrument Setup Software, which runs on a PC under MS Windows. This software can be downloaded from our website at no charge. The required transmitter-to-PC interface cable is available from Laurel (P/N CBL04).

Specifications

Pulse Input	
Signal Types	AC, pulses from NPN, PNP transistors, contact closures, magnetic pickups.
Grounding	Common ground for channels A & B
Channel A Frequency	0.005 Hz to 1 MHz
Channel B Frequency	0.005 Hz to 250 kHz
Minimum Signal	Nine ranges from (-12 to +12 mV) to (+1.25 to +2.1V)
Maximum Signal	250 Vac
Noise Filter	1 MHz, 30 kHz, 250 Hz (selectable)
Contact Debounce	0, 3, 50 ms (selectable)
Analog Output (standard)	
Output Levels	4-20 mA, 0-20 mA, 0-10 Vdc, -10 to +10Vdc (user selectable)
Compliance, 4-20 mA	10V (0-500Ω load)
Compliance, 0-10V	2 mA (5 kΩ load)
Output Resolution	16 bits (65,536 steps)
Output Accuracy	0.02% of output span
Output Update Rate	Programmed gate time + 30 ms + 0-2 signal periods
Output Isolation	250V rms working, 2.3 kV rms per 1 minute test
Sensor Excitation Output (standard)	
Output Levels	5V@100 mA, 10V@120 mA, 24V@50 mA (jumper selectable)
Output Isolation	50V from signal ground
Dual Relay Output (standard)	
Relay Type	Two solid state relays, SPST, normally open, Form A
Load Rating	120 mA at 140 Vac or 180 Vdc
Serial Communications (standard)	
Signal Types	RS232 or RS485 (half or full duplex)
Data Rates	300, 600, 1200, 2400, 4800, 9600, 19200 baud
Output Isolation	250V rms working, 2.3 kV rms per 1 min test
Serial Protocols	Modbus RTU, Modbus ASCII, Laurel ASCII
Modbus Modes	RTU or ASCII
Modbus Compliance	Modbus over Serial Line Specification V1.0 (2002)
Digital Addressing	247 Modbus addresses. Up to 32 devices on an RS485 line without a repeater
Power Input	
Standard Power	85-264 Vac or 90-300 Vdc
Low Power Option	10-48 Vdc or 12-32 Vac
Power Frequency	DC or 47-63 Hz
Power Isolation	250V rms working, 2.3 kV rms per 1 min test
Power Consumption	2W typical, 3W with max excitation output
Mechanical	
Dimensions	129 x 104 x 22.5 mm case
Mounting	35 mm rail per DIN EN 50022
Electrical Connections	Plug-in screw-clamp connectors
Environmental	
Operating Temperature	0°C to 55°C
Storage Temperature	-40°C to 85°C
Relative Humidity	95% at 40°C, non-condensing
Cooling Required	Mount transmitters with ventilation holes at top and bottom. Leave 6 mm (1/4") between transmitters, or force air with a fan.

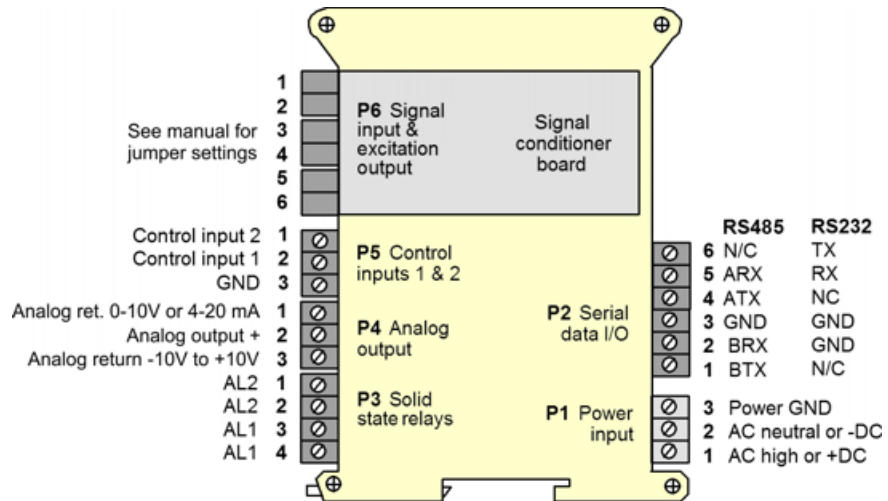

Pinout

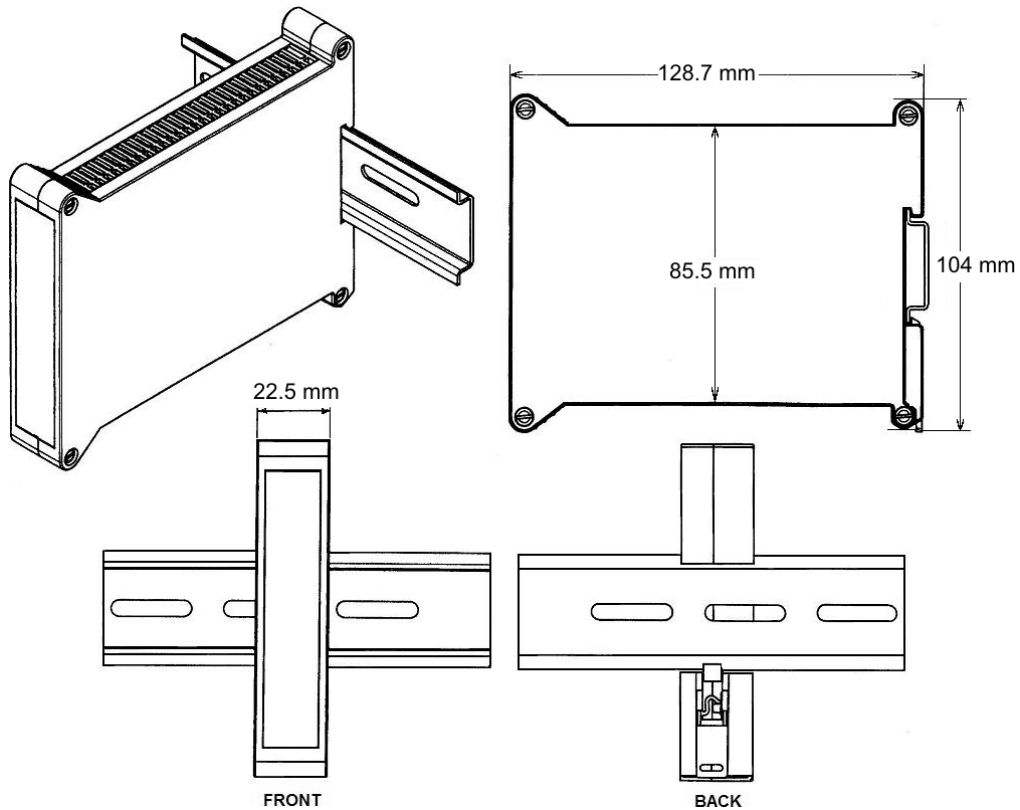

Mechanical

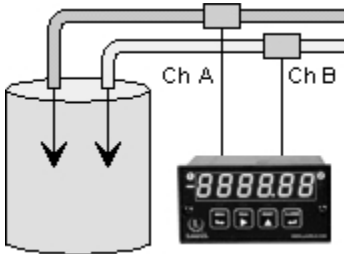
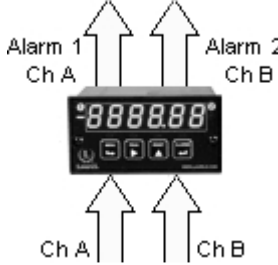

Application Examples of Totalizing Meters and Transmitters

Combining Two Totals	
	<p>A+B, A-B, A/B and AxB arithmetic functions are available with the Extended totalizing transmitter. A+B can sum two totals, while A-B subtracts the outflow total from inflow total. A/B ratio applied to two totals helps assure the proper mixing of components.</p>
Up or Down Counting with Preset	
	<p>A single Laureate dual-channel totalizing transmitter will handle two repetitive fill operations by counting from zero up to a preset, or down from a preset to zero. The dual relay option is required.</p>
Machine ON Time and Utilization	
	<p>An easy way to measure the ON time of machines is to count AC line cycles and scale the total to hours. To display machine utilization or duty cycle in percent, use the Extended totalizing transmitter. Connect Channel A to switched AC and Channel B to the AC line, and apply a 100 multiplier to the A/B ratio.</p>
Custom Curve Linearization	
	<p>The Extended version of the Laureate dual channel totalizing transmitter can transmit scaled rate or total for the same channel at the push of a button, and alarm both the rate and total. The Extended version can also do curve linearization, thereby extending the working range and accuracy of flow transducers.</p>

Ordering Guide

Create a model a model number in this format: **LT60FR, CBL04**

Transmitter Type	LT Laureate 4-20 mA & RS485 Transmitter
Main Board	<p>6 Standard Main Board 8 Extended Main Board</p> <p><i>With Standard Main Board:</i> Scalable to ±999,999 for frequency, rate, square root of rate, up or down total, period, A-to-B time interval. <i>With Extended Main Board:</i> Above, plus rate and total simultaneously, ratio (A/B), draw (A/B-1), other arithmetic functions (AxB, A+B, A-B), phase angle, stopwatch, up/down counting, batching operation, linearization of nonlinear inputs.</p>
Power	<p>0 Isolated 85-264 Vac or 90-300 Vdc 1 Isolated 12-32 Vac or 10-48 Vdc</p>
Input Type	FR Dual-Channel Frequency
Accessories	<p>CBL04 RS232 cable, 7ft. Connects RS232 screw terminals of LT transmitter to DB9 port of PC. CBL02 USB to RS232 adapter cable. Combination of CBL02 and CBL04 connects transmitter RS232 terminals to PC USB port.</p>

