

LT SERIES TRANSMITTERS

ANALOG INPUT
4-20 MA OUTPUT & RS232/RS485 I/O
USER MANUAL



LAUREL Electronics, LLC

3183-G Airway Ave, Costa Mesa, CA, 92626, USA

Tel: (714) 434-6131 • Fax: (714) 434-3766 • Website: <https://www.laurels.com>



Intertek
4006497

1. ORDERING GUIDE

Configure a model number in this format: **LT20DCV1, CBL04**



Transmitter Type

LT.....4-20 mA, 0-20 mA, 0-10V, or -10V to +10V isolated analog output, isolated RS232/RS485 serial data output, two 120 mA solid state relays, and isolated transducer excitation output.

LTE.... 4-20mA, 0-20 mA, 0-10V or -10V to +10V isolated analog output, isolated Ethernet output, two 120 mA solid state relays, and isolated transducer excitation output.



Main Board

2.....Standard main board
4.....Extended main board

Note: Extended main board adds rate of change and custom curve linearization. Not applicable to temperature.



Power

0..... 85-264 Vac or 90-300 Vdc
1..... 12-32 Vac or 10-48 Vdc



Input Type

DC Volts

DCV1.....200.00 mV
DCV2.....2.0000 V
DCV3.....20.000 V
DCV4.....200.00 V
DCV5*.....600.0 V
DCV6.....300.0 V

DC Amperes

DCA1.....2.0000 mA
DCA2.....20.000 mA
DCA3.....200.00 mA
DCA4.....5.000 A

RMS Volts

RMV1 200.00 mV
RMV2 2.0000 V
RMV3 20.000 V
RMV4 200.00 V
RMV5* 600.0 V
RMV6 300.0 V

RMS Amperes

RMA1 2.0000 mA
RMA2 20.000 mA
RMA3 200.00 mA
RMA4 5.000 A

* Range not ETL certified

Process & Ratio Signals

4-20 mA, 0-10V, etc.

P.....4-20 mA in = 4-20 mA out
P1.....Custom Scaling

Specify min input and output, max input and output.

Load Cell & Strain Gauge

4- or 6-wire ratio. Full scale ranges from 20 to 500 mV.

WM1..... -99,999 to +99,999

Specify min input and output, max input & output.

RTD Temperature

Pt100, P385C..... -202 to 850°C
Pt100, P385F.... -331 to 1562°F
Pt100, P392C.... -202 to 850°C
Pt100, P392F.... -331 to 1562°F
Ni120, 672C..... -80 to 260°C
Ni120, 672F..... -112 to 500°F
Cu10, 427C..... -97 to 260°C
Cu10, 427F..... -143 to 500°F

Thermocouple Temperature

JC -210 to 760°C
JF..... -347 to 1400°F
KC..... -244 to 1372°C
KF..... -408 to 2501°F
TC -257 to 400°C
TF -430 to 752°F
EC -240 to 1000°C
EF -400 to 1830°F
NC -245 to 1300°C
NF..... -410 to 2370°F
SC -46 to 1768°C
SF..... -51 to 3214°F
RC..... -45 to 1768°C
RF..... -49 to 3213°F

Resistance

R0.....0-2 ohms (fixed range)
R1.....0-20 ohms
R2.....0-200 ohms
R3.....0-2 kohms
R4.....0-20 kohms
R5.....0-200 kohms
R6.....0-2 Mohms (fixed range)

ACCESSORIES

CBL04.....RS232 cable, transmitter to computer
CBL02.....USB to DB9 adapter cable

2. TABLE OF CONTENTS

1.	Ordering Guide.....	2
2.	Table of Contents.....	3
3.	Product Overview.....	4
4.	Receiving & Unpacking Your Transmitter.....	5
5.	Safety Considerations.....	5
6.	Transmitter Field Wiring.....	6
7.	Programming Your Transmitter.....	8
8.	Opening Your Transmitter Case.....	17
9.	DC Signal Conditioner Board.....	17
10.	AC Signal Conditioner Board.....	19
11.	Load Cell & Microvolt Signal Conditioner Board.....	21
12.	Thermocouple Signal Conditioner Board.....	23
13.	RTD & Ohms Signal Conditioner Board.....	25
14.	Communications, Analog Output and Excitation Settings.....	27
15.	Dual Relay Operation.....	28
16.	Input Signal Filtering.....	31
17.	Transmitter Calibration.....	32
18.	Custom Curve Linearization.....	33
19.	Modbus Protocol Transmitter Communications.....	34
20.	Custom ASCII Protocol Transmitter Communications.....	39
21.	LT Series Analog Input Transmitter Specifications.....	44
22.	Warranty.....	48

3. PRODUCT OVERVIEW

This manual covers LT Series DIN rail transmitters with isolated analog and RS232/RS485 outputs, dual relays, and an analog input signal conditioner. A separate manual covers **LTE Series** DIN rail transmitters with isolated 4-20 mA and Ethernet outputs, dual relays, and an analog input signal conditioner.

LT Series transmitters duplicate the signal conditioning and signal processing features of their 1/8 DIN panel-mounted digital panel meter counterparts for exceptional accuracy at high read rate. A wide range of analog signal sources are accommodated by five analog signal conditioners:

- **DC input** for volts, amps, process signals (e.g., 4-20 mA), and strain gauges. Most sensitive full-scale input range of 200 mV. Built-in 5A current shunt.
- **AC rms input** for volts and amps. Can be AC or DC coupled. Built-in 5A current shunt.
- **Load cell or microvolt input** with selectable full-scale input ranges from 20 mV to 500 mV.
- **Thermocouple temperature input** for seven thermocouple types.
- **RTD temperature or Ohms input** for Pt100, Ni120 or Cu10 RTDs, or 20 Ω -200 k Ω resistance.

A 4-20 mA, 0-20 mA, 0-10V, or -10V to +10V isolated analog output is standard. This output is generated by an ultra-linear 16-bit digital-to-analog converter which tracks an internal linearized digital reading.

Isolated serial communications are standard. The transmitter serial port is default jumpered for RS232 or full-duplex RS485 (same jumper settings). Half-duplex RS485 is also selectable either via internal or external jumpers. Three serial protocols are software selectable: Modbus RTU, Modbus ASCII and Custom ASCII. Modbus allows devices by different manufacturers to be addressed on the same data line. The simpler Custom ASCII protocol is recommended when there are no devices by other manufacturers on the data line.

An isolated transducer excitation output is standard, in DC, process and load cell input models. Three output levels are jumper selectable: 5V at 100 mA, 10V at 120 mA, 12V at 140 mA, or 24V at 50 mA. The factory default setting is 10V and can power up to four 350 ohm load cells in parallel.

Two isolated solid state relays are standard. These are rated 120 mA at 140 Vac or 180 Vdc.

Isolation to 250V rms is provided for power, signal input, analog output, relay outputs, and communications. Isolation adds safety and avoids possible ground loops. The transducer excitation output is isolated to $\pm 50V$ from signal ground.

Internal jumpers are used to select the signal range, analog output type, communication type, and excitation level. The transmitter configuration is specified by the model number on the transmitter label. A user can reconfigure the transmitter by opening the case and moving jumpers.

Transmitter scaling is via serial connection to a PC using MS Windows based Instrument Setup Software, which can be downloaded at no charge. The required transmitter-to-PC interface cable

is available for purchase.

4. RECEIVING & UNPACKING YOUR TRANSMITTER

Your transmitter was carefully tested and inspected prior to shipment. Should the transmitter be damaged in shipment, notify the freight carrier immediately. In the event the transmitter is not configured as ordered or is inoperable, return it to the place of purchase for repair or replacement. Please include a detailed description of the problem.

5. SAFETY CONSIDERATIONS



Warnings: Use of this transmitter in a manner other than specified may impair the protection of the device and subject the user to a hazard. Do not attempt to operate if the unit shows visible damage.

- This unit may be from 85-264 Vac or with the worldwide voltage power supply option, or from 12-32 Vac or 10-48 Vdc with the low voltage power supply option. Verify that the proper power option is installed for the power to be used.
- The 85-264 Vac power connector (P1 Pins 1-3) is colored **Green** to differentiate it from other input and output connectors. The 12-32 Vac or 10-48 Vdc power connector is colored **Black**. This transmitter has no power switch. It will be in operation as soon as power is applied.
- **The analog output is sourcing.** Do not connect the 4-20 mA analog output to a load designed to apply 24 Vdc to a two-wire transmitter. Applying 24 Vdc will burn out the main board.
- To avoid dangers of electrocution and/or short circuit, do not attempt to open the case while the unit is under power.
- To prevent an electrical or fire hazard, do not expose the transmitter to excessive moisture. Do not operate the transmitter in the presence of flammable gases or fumes, as such an environment constitutes an explosion hazard.

Symbols applicable to this product:



Caution (refer to accompanying documents)



Caution, risk of electric shock.



Equipment protected throughout by double insulation or reinforced insulation.



CE Mark. Indicates that product meets EU safety, health and environmental requirements.



Earth (ground) terminal.



Both direct and alternating current.



ETL Mark. Indicates that product conforms to UL Std. 61010-1 and is certified to CAN/USA Std. C22.2 No. 61010-1

Operating environment:

Transmitter Class II (double insulated) equipment designed for use in Pollution degree 2.

6. TRANSMITTER FIELD WIRING

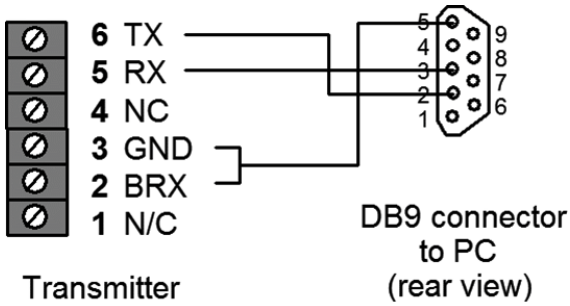
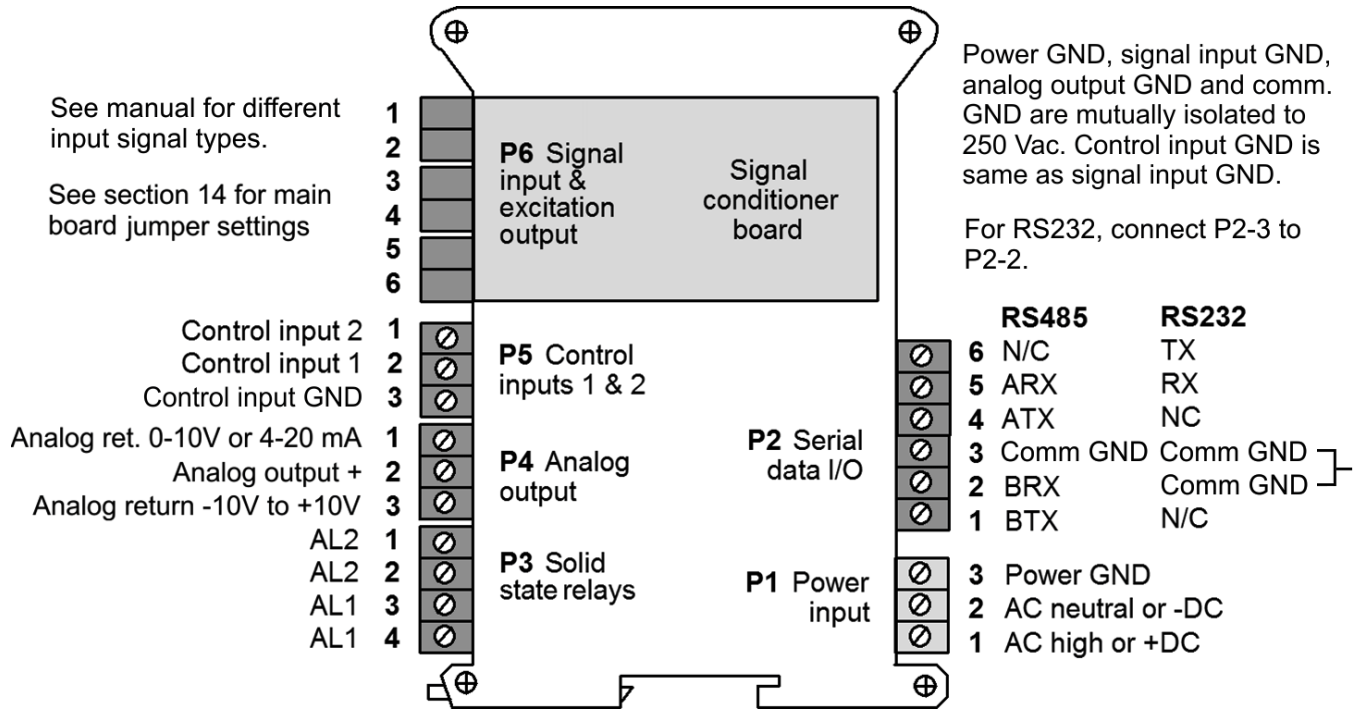

RS232 wiring

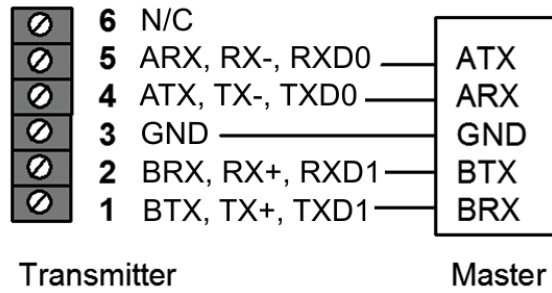

RS485 wiring, full duplex

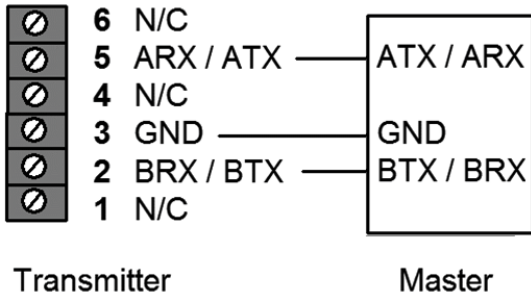

RS485 wiring, half duplex with internal jumpers.

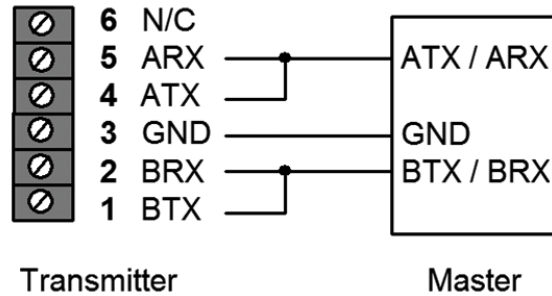

RS485 wiring, half duplex with external jumpers.

P6 - SIGNAL INPUT DETAIL

DC & Externally Powered Process

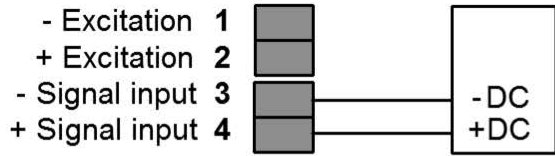

2-Wire Process Transmitter

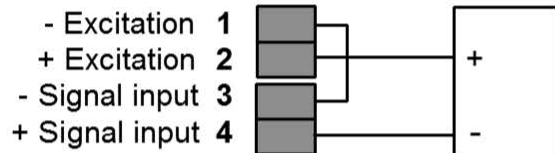

DC Ratio

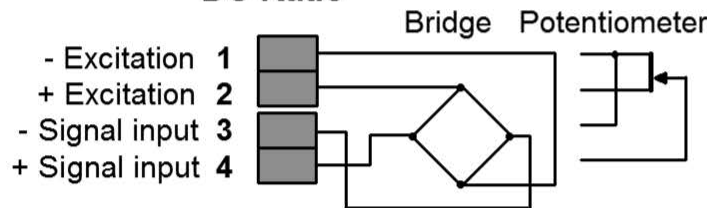

AC & AC+DC True RMS

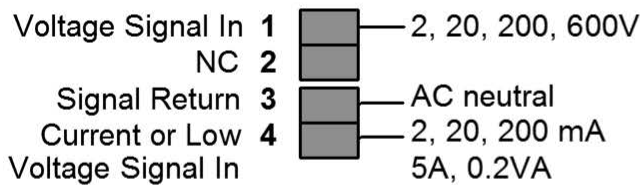

Thermocouple

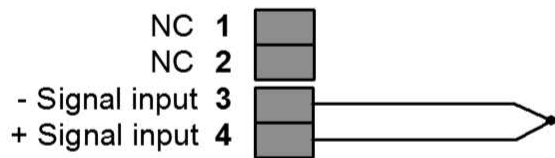

MOUNTING FOR COOLING

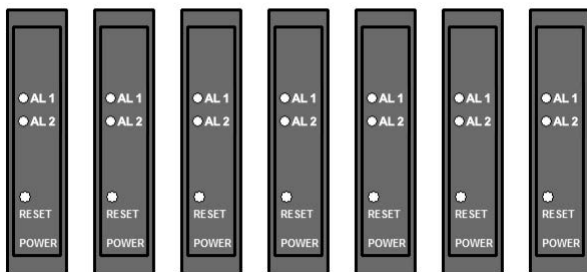

Mount transmitters with ventilation holes at top and bottom. Leave minimum of 6 mm (1/4") between transmitters, or force air with a fan.

Load Cell

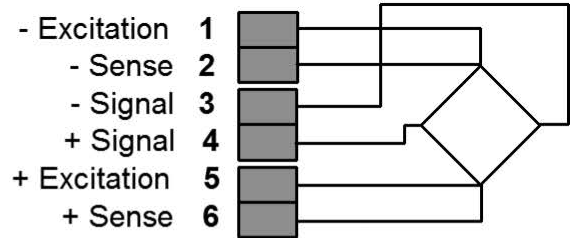

For 4-wire load cell connection, jumper Pin1 to Pin 2, and Pin 5 to Pin 6.

RTD or Resistance - 2 Wire

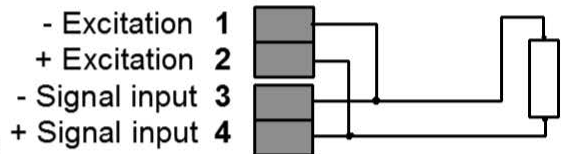

RTD or Resistance - 3 Wire

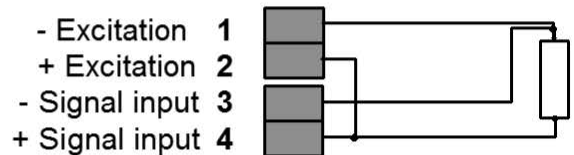

RTD or Resistance - 4 Wire

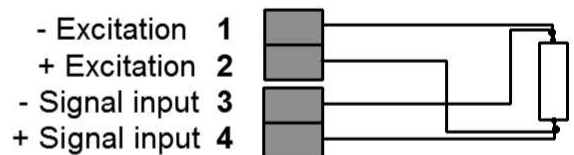

P4 - ANALOG OUTPUT DETAIL

Unipolar Output (0-10V, 4-20 mA)

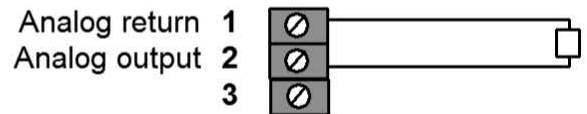

Bipolar Output (-10V to +10V)

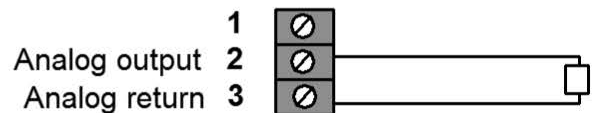

500 Ohms max load for 4-20 mA,
5 kOhms min for 0-10V or -10V to +10V

Analog output is sourcing. Do not apply external voltage. External 24 Vdc power will damage the analog output section.

7. PROGRAMMING YOUR TRANSMITTER

Our transmitters are easily programmed using a PC and **Instrument Setup (IS) Software**, which runs under MS Windows and provides a graphical user interface. This software allows uploading, editing, downloading and saving of setup data, execution of commands under computer control, listing, plotting and graphing of data, and computer prompted calibration.

USING INSTRUMENT SETUP SOFTWARE

As a first step, set User Account Control (UAC) of your version of Windows to "Never notify" so that Instrument Setup Software can create directories. Use Google for instructions. Power down and restart your computer for the UAC change to take effect.

RS232 cable with rear view of DB9 connector to PC

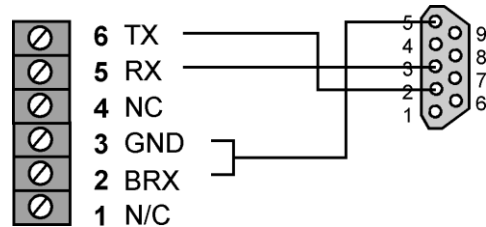

Use a 3-wire RS232 cable (P/N CBL04) to connect your transmitter to the COM port of your PC. Download the file ISx_x_x.exe from our website and double-click on the file name. Click on "Install Instrument Setup Software" and follow the prompts.

To launch IS software, press on Start => Programs => IS2 => Instrument Setup or on the desktop shortcut that you may have created. Following a brief splash screen, the Communications Setup screen below will appear.

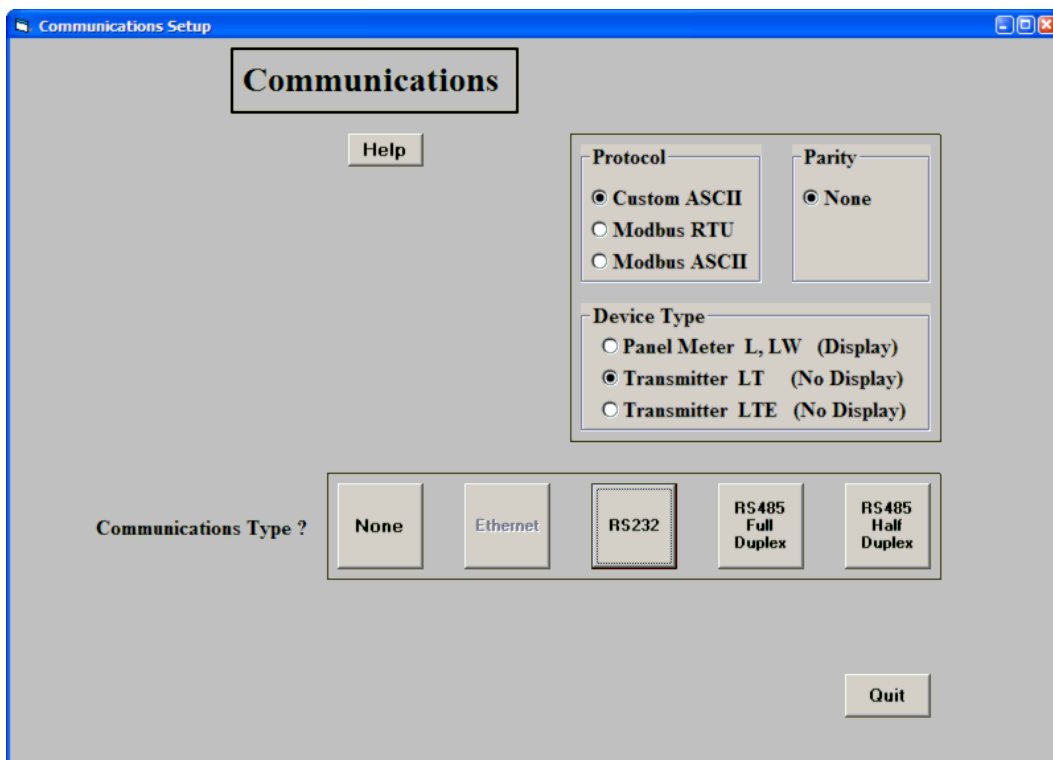

In the Communications Setup screen, select the “Custom ASCII” as the protocol, as this is the factory default setting. Select “Transmitter LT” as the Device Type and RS232 the Communications Type. This will take you to the Establish Communications screen.

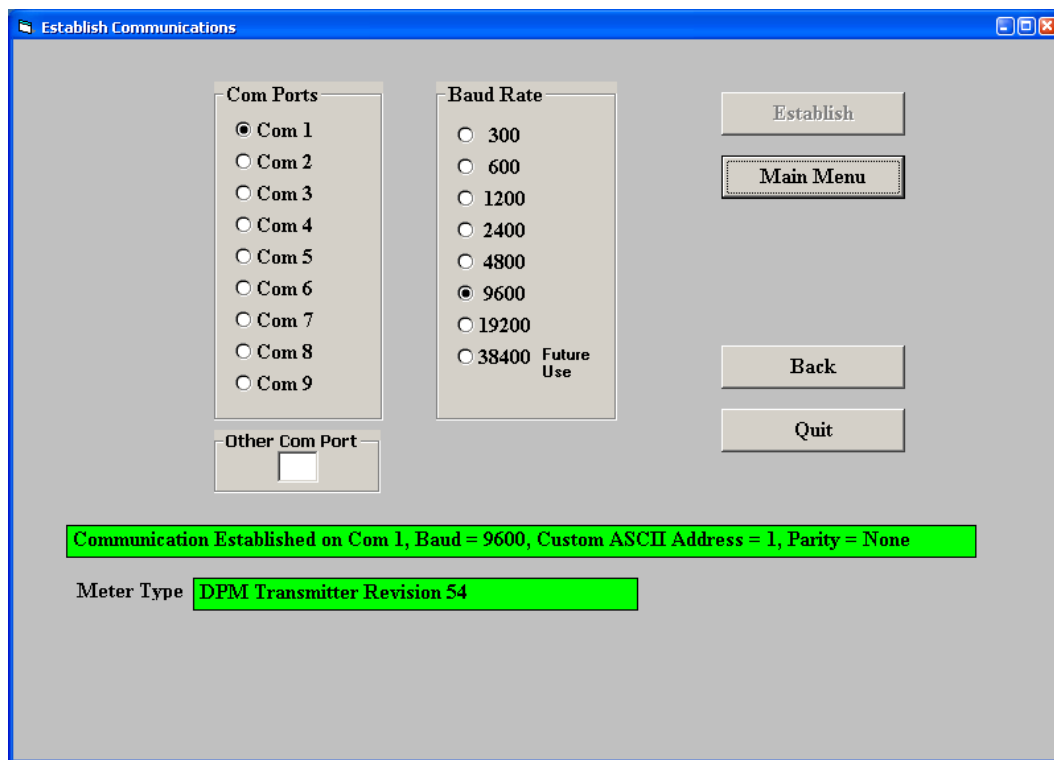

In the Establish Communications screen, select your Com Port and 9600 and the Baud Rate. You will be able to change your protocol and baud rate later under the Communication setup tab. Click on Establish, and the two fields at the bottom of the screen should turn green. Click on the Main Menu button.

From the Main Menu, click on DPM => Get Setup to retrieve (or get) the existing setup data from your DPM transmitter. Click on View => Setup to bring up screens which allow you to easily edit the setup file using pull-down menus and other selection tools. You can download (or put) your edited file into the transmitter by clicking on DPM => Put Setup. You can save your setup file to disk by clicking on File => Save Setup and retrieve a previously saved file from disk by click on File => Open.

The best way to learn IS software is to experiment with it.

For context-sensitive help for any data entry field under any tab, select that field and press the F1 key.

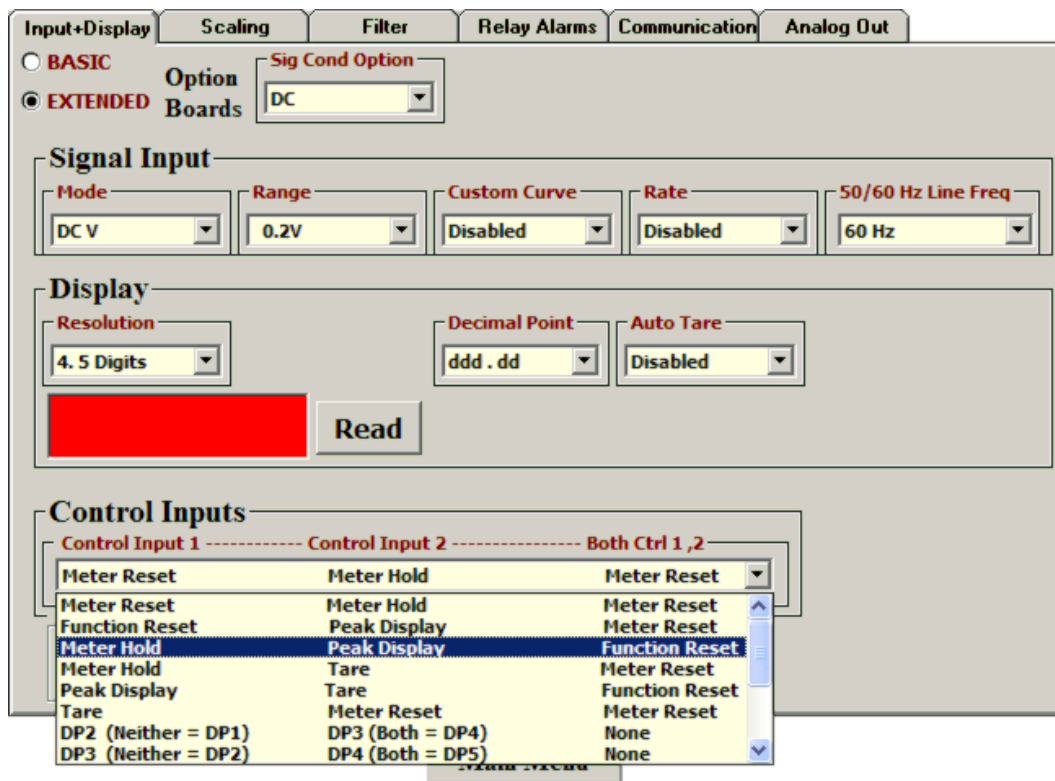

To get to the Input+Display tab, click on DPM => Get Setup to retrieve the current setup information from your DPM transmitter, then on View => Setup. Use the Input+Display screen to set up Signal Input, Display, and Control Inputs. The software reads the signal conditioner type, but not the range, which is set by jumpers. The “50/60 Hz Line Freq” selection is used to optimize filtering for 50 or 60 Hz electrical noise.

For ratiometric operation with a DC signal conditioner, set the Signal Input Mode to Ratio. In this mode, the transmitter tracks a ratio of the applied excitation voltage and is unaffected by changes in the excitation voltage. This capability is used for resistive bridge sensors and voltage dividers, such as potentiometers which track wiper position.

Clicking on the Control Inputs field opens a pull-down menu which allows selection of the roles of Control Input 1, Control Input 2, and simultaneous Control Inputs 1 and 2. For example, with a DC signal conditioner and the highlighted selection, grounding Control Input 1 places the transmitter on Hold, grounding Control Input 2 causes the Peak reading to be transmitted, and grounding both Control Inputs 1 and 2 causes a Function Reset, which resets Peak, Valley and latched alarms. Note that the roles of the Control Inputs vary with the type of signal conditioner. Only the applicable roles will be displayed.

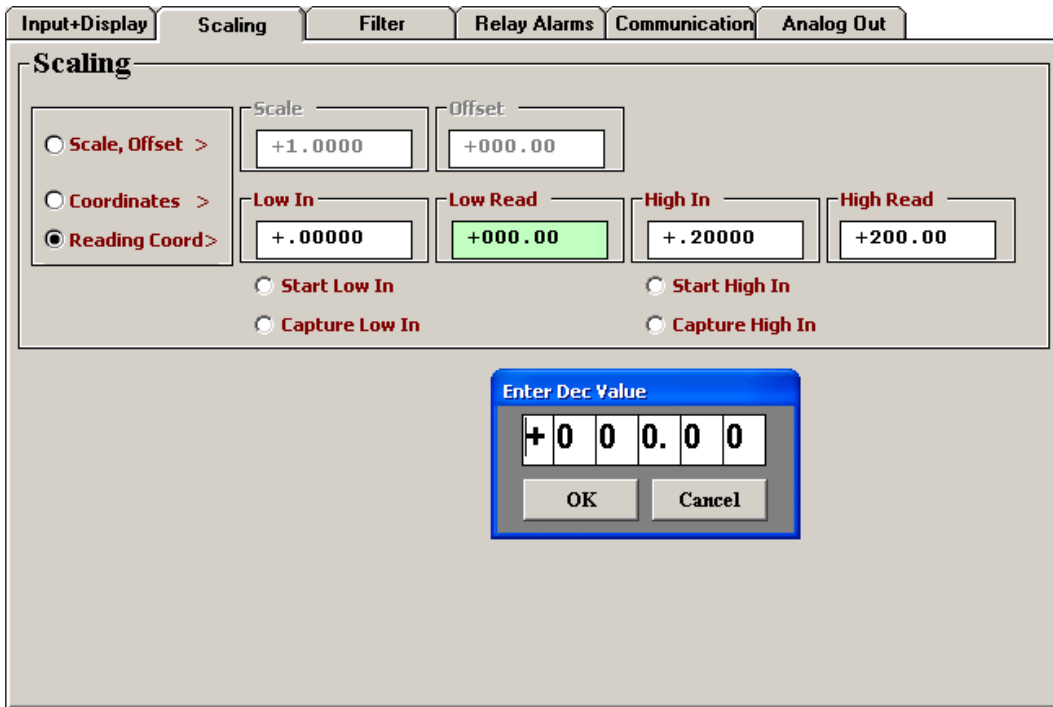

Click on the Scaling tab to scale your transmitter. You will be given the choice of three scaling methods for inputs other than temperature: 1) Scale and Offset method, 2) Coordinates of 2 points method where (Low In, Low Read) and (High In, High Read) data points are entered numerically, and 3) Reading Coordinates of 2 points method, which uses actual readings.



Click on the Filter tab to set to set up filtering for your readings. The filter time constant can be automatic, be specified in seconds, or be turned off. The adaptive threshold modifies the time constant in response to noise. A low adaptive threshold is recommended for normal low noise. A high adaptive threshold is recommended for high noise environments.

Input+Display	Scaling	Filter	Relay Alarms	Communication	Analog Out
Alarm 1 Setpoint 1 <input type="text" value="+010000."/>		Alarm 2 Setpoint 2 <input type="text" value="+020000."/>			
Deviation 1 <input type="text" value="+000000."/>		Deviation 2 <input type="text" value="+000000."/>			
Alarm 1 Source <input type="text" value="Filtered"/>		Alarm 2 Source <input type="text" value="Filtered"/>			
Alarm 1 State <input type="text" value="Disabled"/>		Alarm 2 State <input type="text" value="Disabled"/>			
Relay1 Alarm State <input type="text" value="Active On"/>		Relay2 Alarm State <input type="text" value="Active On"/>			
Deviation 1 Type <input type="text" value="Hysteresis"/>		Deviation 2 Type <input type="text" value="Hysteresis"/>			
Alarm 1 Type <input type="text" value="Non-Latching"/>		Alarm 2 Type <input type="text" value="Non-Latching"/>			
Alarms 1,2 No. Rdgs to Alarm <input type="text" value="1 Reading"/>					

Click on the Relay Alarms tab to set up your transmitter's two solid state relays, which are standard. For detailed help on any data entry field under, select that field and press the F1 key.

Input+Display	Scaling	Filter	Relay Alarms	Communication	Analog Out
Serial Communications					
Baud Rate <input type="text" value="9600"/>	Address <input type="text" value="1"/>	Output Items <input type="text" value="Item 1"/>	Output Filter <input type="text" value="Unfiltered"/>	Output Rate <input type="text" value="Read Rate"/>	
Output Mode <input type="text" value="Command"/>	<input type="checkbox"/> Incl Alarm Data <input type="checkbox"/> Include LF	CR (LF) <input type="text" value="At End of All"/>	Full/Half Duplex <input type="text" value="Full Duplex"/>		
Serial Protocol <input type="text" value="Custom ASCII"/>					
Recognition Char <input type="text" value="Standard *"/>	Transmission Chars <input type="text" value="No Special Char"/>				

Click on the Communication tab to view the communication parameters that you used to establish default communications with your transmitter. You can reselect Baud Rate, Device Address, Serial Protocol, and Full or Half Duplex, even though you may have selected different values to establish initial communications with your PC. Select Full Duplex, not Half Duplex, even if you are using half-duplex RS485 wiring.

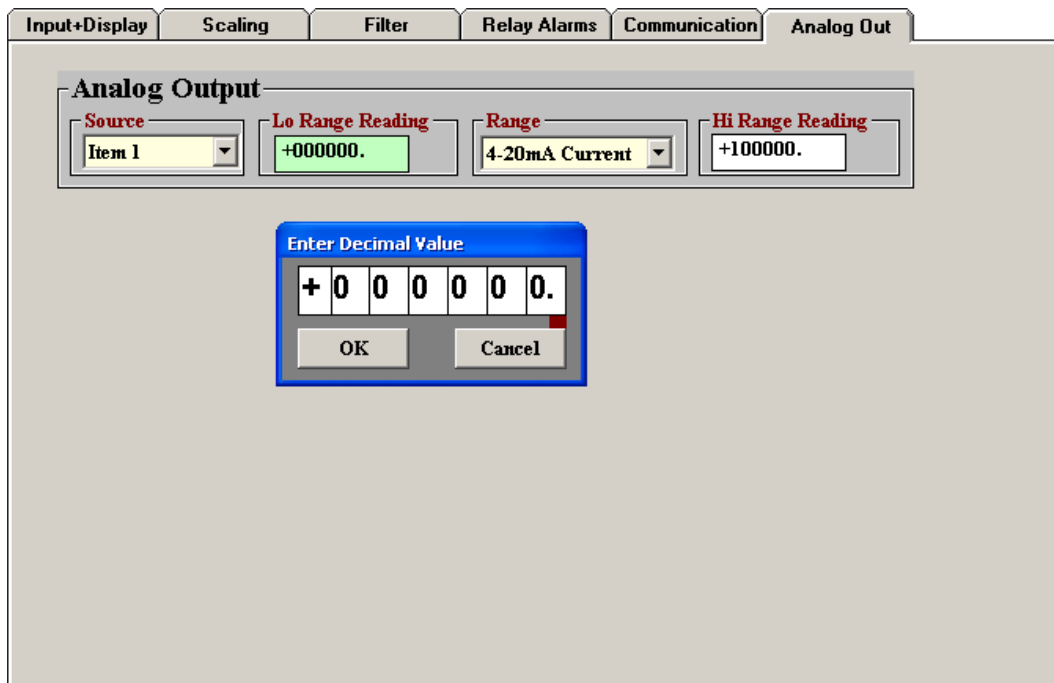

Click on the Analog Out tab to scale your analog output, which is standard. Under Range, select 0-20 mA current, 4-20 mA current, 0-10V voltage, or -10V to +10V voltage. Type in your Lo Range Reading and Hi Range reading. These will create the two endpoints of your analog output range.

For detailed help on any data entry field, select that field and press the F1 key.

ADDITIONAL INSTRUMENT SETUP PROGRAM FEATURES

- **The Commands pull-down menu** allows you to execute certain functions by using your computer mouse. This menu will be grayed out unless a *Get Setup* has been executed.
- **The Readings pull-down menu** provides three formats to display input data on your PC monitor. Use the *Pause* and *Continue* buttons to control the timing of data collection, then press *Print* for a hardcopy on your PC printer.
 - **List** presents the latest internal readings in a 20-row by 10-column table. Press *Pause* at any time to freeze the display. Press *Print* for a hardcopy.
 - **Plot** generates a plot of internal readings vs. time in seconds. It effectively turns the transmitter-PC combination into a printing digital oscilloscope.
 - **Graph** generates a histogram, where the horizontal axis is the internal reading, and the vertical axis is the number of occurrences of readings. The display continually resizes itself as the number of readings increases.

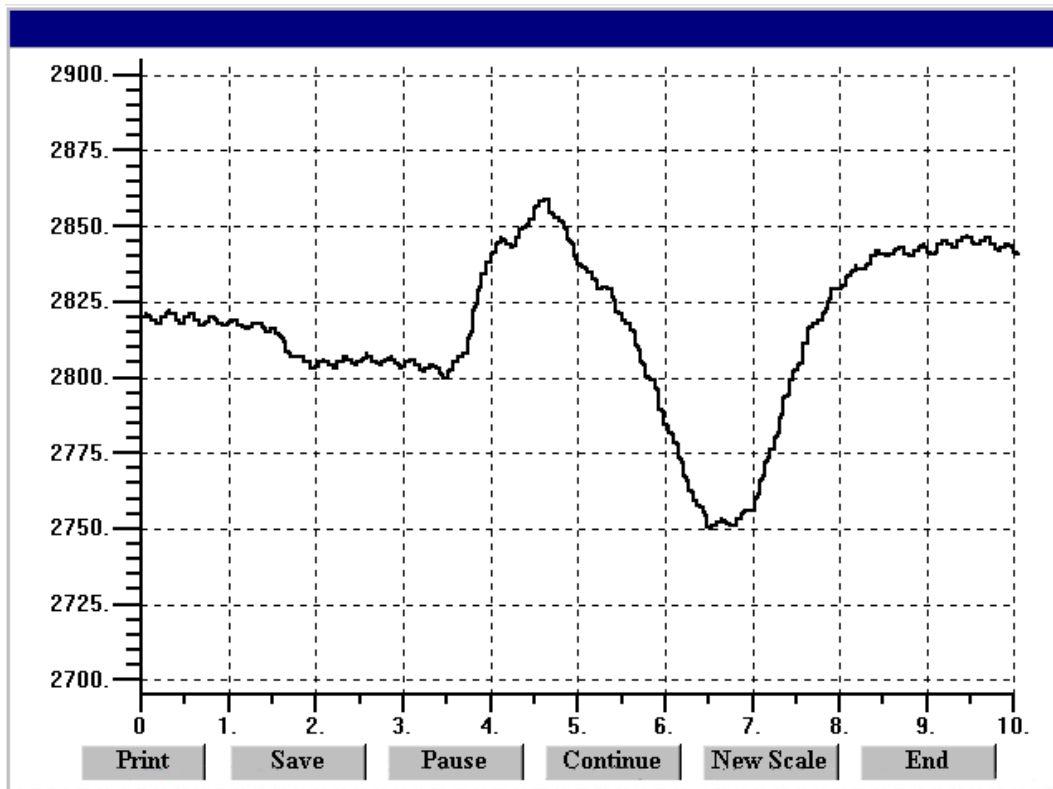

Plot

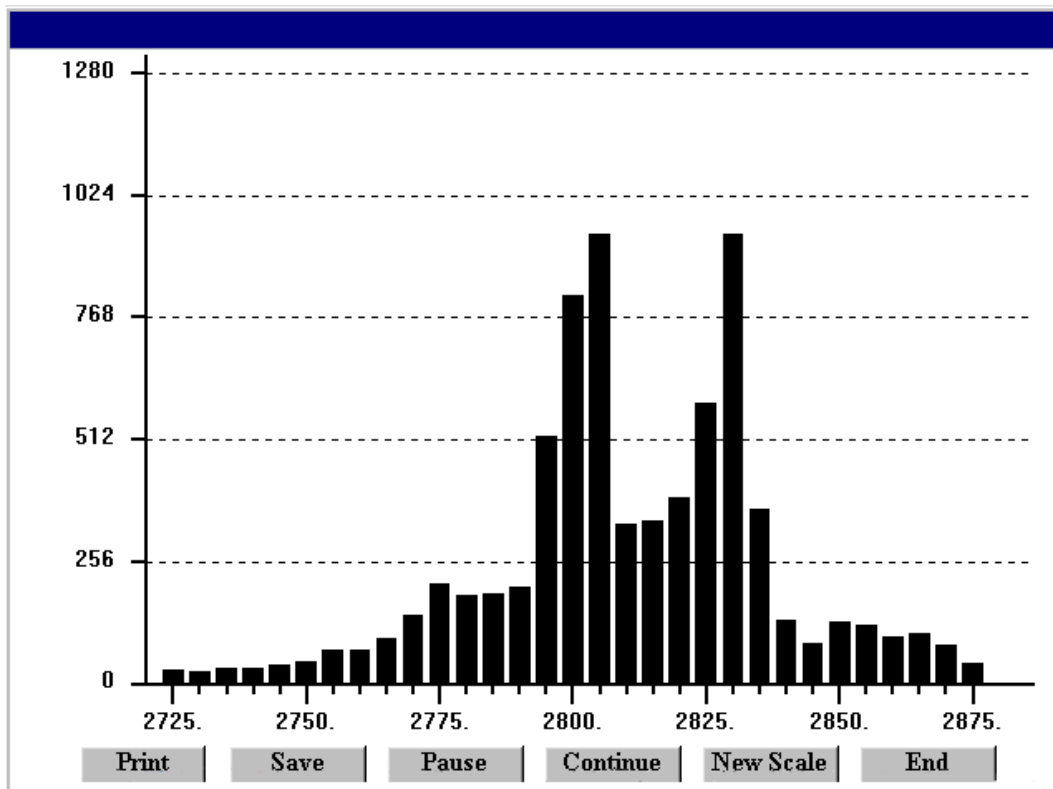

Graph

- **The Jumpers pull-down menu** shows jumper positions for the selected signal conditioner boards and the main board, duplicating information in this manual.

DC Signal Conditioner Jumpers

DC Signal Conditioner

Example of jumper installed "a"

Voltage		Current	
Input Range	Jumper Positions	Input Range	Jumper Positions
200 mV	E, b	2 mA	D, h, b
2 V	E, a	20 mA	C, h, b
20 V	F, g, b	200 mA	B, h, b
200 V	F, g, a	5 A	A, h, b
660 V	F, h, a		

Notes:

1. Click on Jumpers/Power Supply to select jumpers for 5, 10 or 24V Excitation.
2. Upper case letter positions require 5mm(.2in) jumpers, lower case 2.5mm(0.1in) jumpers.
3. Store spare jumpers on single unused jumper posts NOT associated with upper case letters.

Print OK

8. OPENING YOUR TRANSMITTER CASE

WHEN TO CHANGE JUMPERS

Your transmitter case does not need to be opened if jumpers have already been set by your distributor. Otherwise you will need to open the case and either set jumpers or verify that the factory default jumper positions will meet your needs. Note that while Instrument Setup Software senses the circuit board type, it does not sense jumper settings, and the corresponding information has to be entered manually. Jumpers are used for the following:

- 1) **On the signal conditioner board** to set the signal type (e.g., voltage or current) and the range. For details, please see the next five sections of this manual. Note that all ranges of all signal conditioner boards are factory calibrated, with calibration factors stored in EPROM on the board.
- 2) **On the main board** to set the serial communication signal (RS232 or RS485), termination resistor for long cable runs, analog output signal (current or voltage), and sensor excitation output (5V, 10V, 12V or 24V). Default factory settings are current output, RS232, no termination resistor, and 10V excitation.

HOW TO OPEN & CLOSE THE CASE



The two clamshell halves of the case are held together with a bolt and a nut at each of the four corners. Use a Phillips screwdriver to remove the four bolts. The nut will then drop off, and the clamshell halves will separate. When closing the case, make sure that the ventilation grills are properly aligned.



Caution: The nuts at each corner are not captive and are black. Take precautions so that the nuts do not get lost.

9. DC SIGNAL CONDITIONER BOARD (DC, PROCESS, RATIO)

The DC volts, DC amps and process transmitters utilize the DC signal conditioner board, which needs to be configured via jumpers for the desired voltage or current range. All signal ranges are factory calibrated with calibration factors stored in EEPROM on the signal conditioner board. Instrument Setup Software recognizes the board and brings up the appropriate menu items for it; however, it does not recognize the jumper settings. The excitation output can be set to 5V @ 100 mA, 10V @ 120 mA, 12V @ 140 mA, or 24V @ 50 mA via main board jumper settings. Please see Section 14 of this manual.

Board Revisions Q and R

Voltage Ranges

Jumpers

FS Input	E1	E2	E3
±200.00 mV	A	f	b
±2.0000 V	A	f	a
±20.000 V	B	h	b
±200.00 V	B	h	a
±300.0V	B	g	a
±600.0V (not ETL)	B	g	a

Current Ranges

Jumpers

FS Input	E1	E2	E3
±2.0000 mA	A	e, g	b
±20.000 mA	A	d, g	b
±200.00 mA	A	c, g	b
±5.000 A	A	a, b, g	b

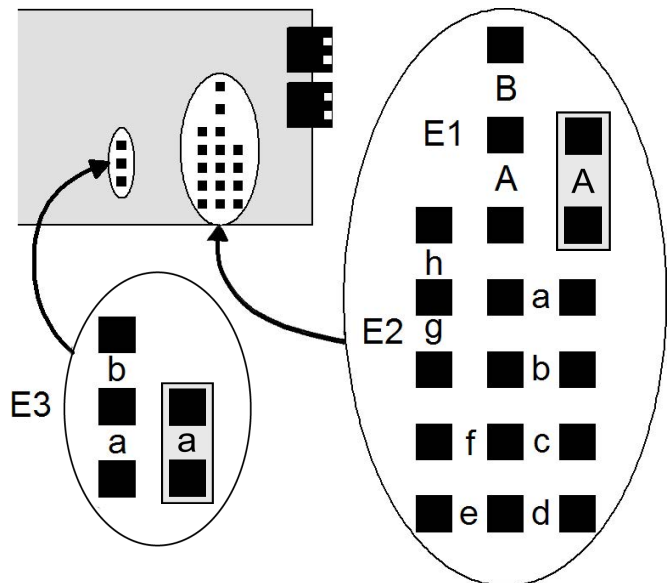

Examples of jumpered positions "A" and "a"

1. Use 5 mm (0.2") jumpers for locations E1 designated by a capital letter.
2. Use 2.5 mm (0.1") jumpers for locations E2 and E3 designated by a lower case letter.
3. Store spare jumpers on an unused jumper post not associated with a capital letter.

For process & DC ratio, three scaling methods can be selected in Instrument Setup Software: 1) Scale and offset, 2) Coordinates of 2 points, and 3) Reading coordinates of 2 points, which uses actual signals. Only menu items applicable to the selected method are presented. Full-scale ranges are ±20000 counts. For resolution purposes, the 300V and 600V ranges are 2000V (100 mV/count), and the 5A range is 20A (1 mA/count).

For use with load cells, select 5V or 10V excitation, set Mode to Ratio, and set Range to 0.2V. The transmitter will then use the excitation voltage as the reference for A-to-D conversion, thereby correcting for any variations in excitation voltage. The excitation can drive four 350-ohm load cells in parallel.

For use with potentiometers, where excitation and signal share the same ground, select 5V (not 10V) excitation, set Mode to Ratio, and set Range to 0.2V. Again, the meter will use the excitation voltage as the reference for A-to-D conversion. Often used for length measurement.

Example: Transmit the digital reading in amps and as 4-20 mA from a 500-100 current shunt

Application: Use a 500-100 (500A, 100 mV) current shunt. Digitally transmit the DC current reading in amps with 0.1A resolution. Also transmit a 4-20 mA signal corresponding to 0-200A.

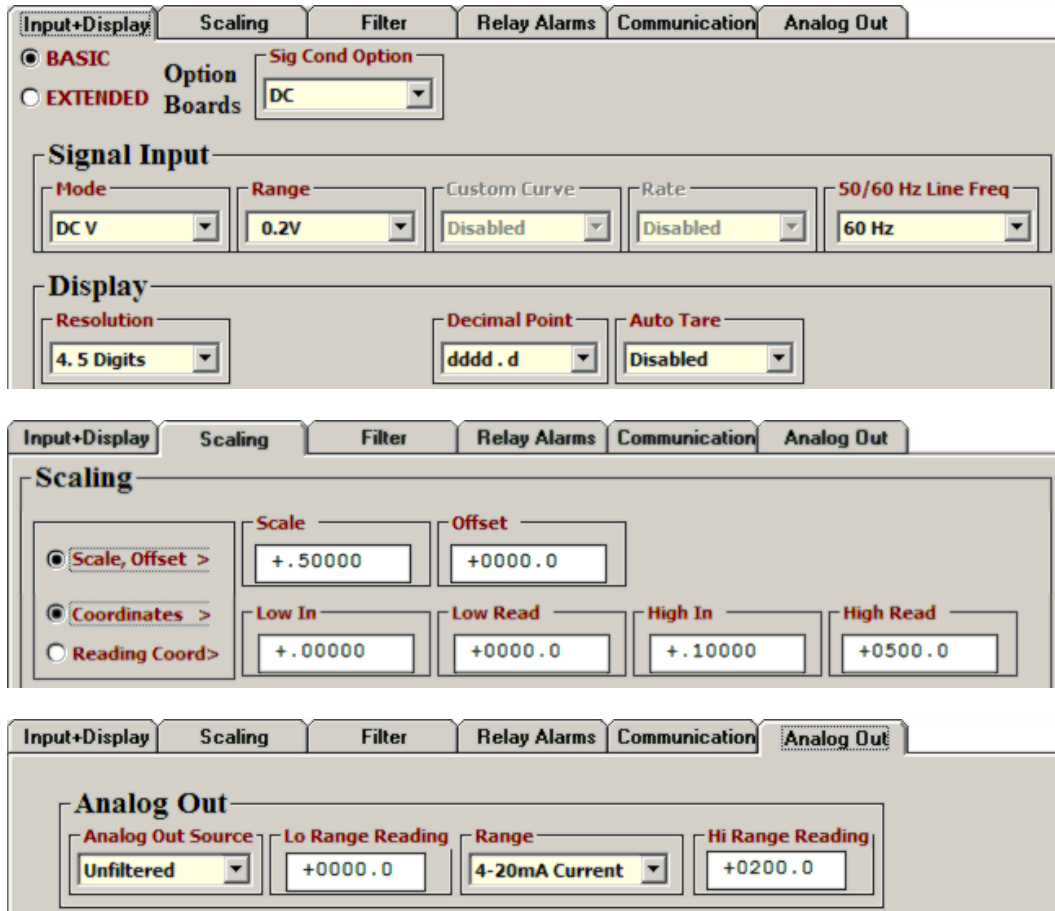

Solution:

- Jumper signal conditioner for ± 200.00 mV range.
- Under “Input+Display” tab, set “Option Board” to DC, Mode to DC V, Range to 0.2V, “Decimal Point” to dddd.d, and noise rejection to “50/60 Hz Line Freq.”
- Under Scaling tab, if Coordinates is selected, set “High In” to 0.1V and “High Read” to 500.0A. For this application, Coordinates is the easiest, most intuitive scaling method.
- Under Scaling tab, if “Scale, Offset” method is selected, set Scale to 0.5. The reason is that a 200 mV full-scale input corresponds to 20,000 input counts, where each input count is 10 μ V (as for the 200 mV scale of a 4-digit meter). These 20,000 input counts need to correspond to 10,000 output counts, where each output count is 0.1A.
- Under “Analog Out” tab, set Range to “4-20 mA current”, “Lo Range Reading” to 0.0A, and “Hi Range Reading” to 200.0A.

10. AC RMS SIGNAL CONDITIONER BOARD

Five RMS voltage and four RMS current ranges are jumper selectable, as is AC or DC coupling. All signal ranges are factory calibrated with calibration factors stored in EEPROM on the signal conditioner board. Instrument Setup Software recognizes the board and brings up the appropriate menu items for it; however, it does not recognize the jumper settings. Ranges also have to be entered manually.

Board Revision S

Voltage Ranges	Jumpers
200.00 mV	j
2.0000 V	c, g, h
20.000 V	c, i
200.00 V	c, k
300.0V & 600.0 V	c, m
Current Ranges	Jumpers
2.0000 mA	l, k
20.000 mA	b, m
200.00 mA	a, m
5.000 A	c, d, e, m
Signal Coupling	Jumpers
AC + DC	f
AC only	none

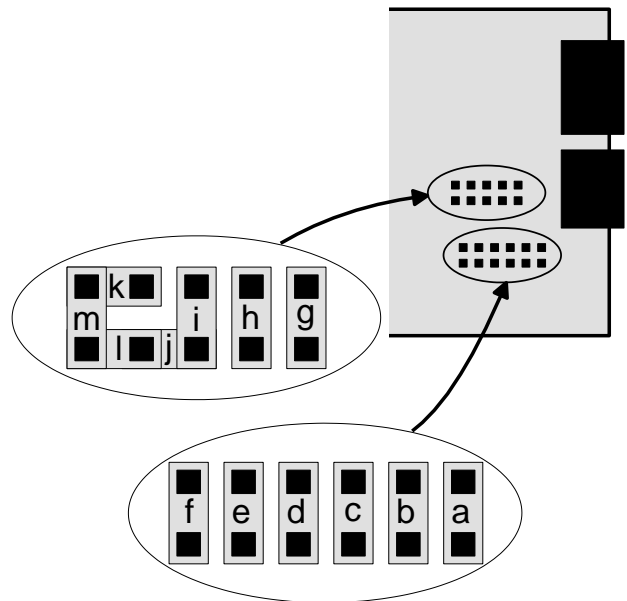

The flexible noise shield may be removed for jumper setting, but must then be reinstalled.

1. Use 2.5 mm (0.1") jumpers.
2. Store spare jumpers on an unused jumper post.
3. OK to remove the plug-in shield for jumper setting, but reinstall before closing the case.

To minimize noise pickup, the input signal wiring should utilize a shielded twisted pair, and the shield should be connected to signal low at the rms board, as illustrated below. If signal low is close to earth ground, such as within 2V, signal low can further be connected to earth ground.

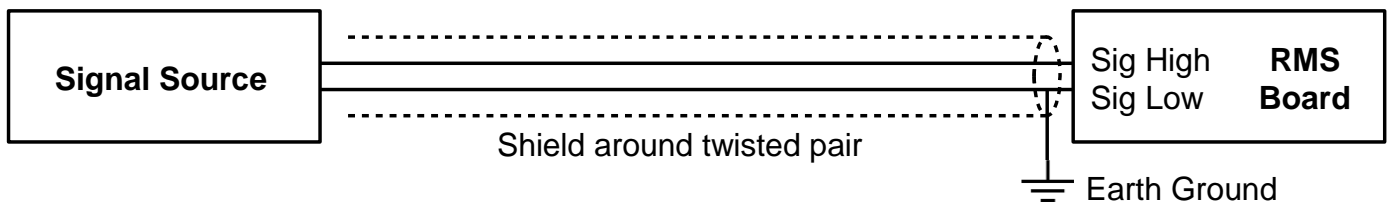

Shielding for AC noise reduction

Example: Transmit the digital reading in amps and as 4-20 mA from an AC current transformer

Application: Use a 200:5 (200A in, 5A out) AC current transformer. Digitally transmit the AC current reading in amps with 0.1A resolution. Also transmit a 4-20 mA signal corresponding to 0-100A.

The image shows three screenshots of a configuration interface for a device, likely a meter or controller, with tabs for Input+Display, Scaling, Filter, Relay Alarms, Communication, and Analog Out.

Input+Display Tab:

- Option Boards:** BASIC (selected), EXTENDED
- Sig Cond Option:** True RMS
- Signal Input:**
 - Mode: RMS A
 - Range: 5.0A
 - Custom Curve: Disabled
 - Rate: Disabled
 - 50/60 Hz Line Freq: 60 Hz
- Display:**
 - Resolution: 4.5 Digits
 - Decimal Point: dddd.d
 - Auto Tare: Disabled

Scaling Tab:

- Scale, Offset >** (selected): Scale: +.40000, Offset: +0000.0
- Coordinates >** (selected): Low In: +00.000, Low Read: +0000.0, High In: +05.000, High Read: +0200.0
- Reading Coord >** (unselected)

Analog Out Tab:

- Analog Out Source:** Unfiltered
- Lo Range Reading:** +0000.0
- Range:** 4-20mA Current
- Hi Range Reading:** +0100.0

Solution:

- Jumper signal conditioner for 5.000 A current range and AC coupling.
- Under “Input+Display” tab, set “Option Board” to True RMS, Mode to RMS A, Range to 5.0A, “Decimal Point” to dddd.d, and “50/60 Hz Line Freq” to 60 Hz to reject 60 Hz noise.
- Under Scaling tab, if Coordinates is selected, set “High In” to 5.000A and “High Read” to 200.0A. For this application, Coordinates is the easiest, most intuitive scaling method.
- Under Scaling tab, if “Scale, Offset” method is selected, set Scale to 0.4. The reason is that a 5A full-scale input corresponds to 5,000 input counts, where each input count is 1 mA (as for the 5A scale of a 4-digit meter). These 5,000 input counts need to correspond to 2,000 output counts, where each output count is 0.1A.
- Under “Analog Out” tab, set Range to “4-20 mA current”, “Lo Range Reading” to 0.0A, and “Hi Range Reading” to 100.0A.

11. LOAD CELL & MICROVOLT SIGNAL CONDITIONER BOARD

The **load cell signal conditioner board** offers sensitivity to ± 20 mV full-scale and 4 or 6-wire load cell connection. This board needs to be configured via jumpers for the desired full-scale voltage range. All ranges are factory calibrated with calibration factors stored in EEPROM. Instrument Setup Software recognizes the board and will bring up the appropriate menu items for it; however, it does not recognize the jumper settings. The ranges also have to be selected in Instrument Setup software. The excitation output can be set to 5V @ 100 mA, 10V @ 120 mA, or 24V @ 50 mA via main board jumper settings. Please see Section 14 of this manual. Operation is ratiometric, with automatic compensation for changes in excitation voltage.

For DC microvolt applications, a scale factor of 1 and an offset of 0 are used for direct readings in microvolts or millivolts. Decimal point selection does not affect the displayed digits. For example, 20 mV can be transmitted as 20.000 mV or 20000 μ V. The decimal point is set separately.

For load cell applications, three scaling methods can be selected in Instrument Setup Software: 1) Scale and offset, 2) Coordinates of 2 points, and 3) Reading coordinates of 2 points, which uses actual signals. Only menu items applicable to the selected scaling method will be presented.

Load Cell & Microvolt Ranges

FS Input	Jumpers	FS Counts
± 20.000 mV	e	± 20000
± 50.000 mV	a	± 50000
± 100.00 mV	b	± 10000
± 250.00 mV	c	± 25000
± 500.00 mV	d	± 50000

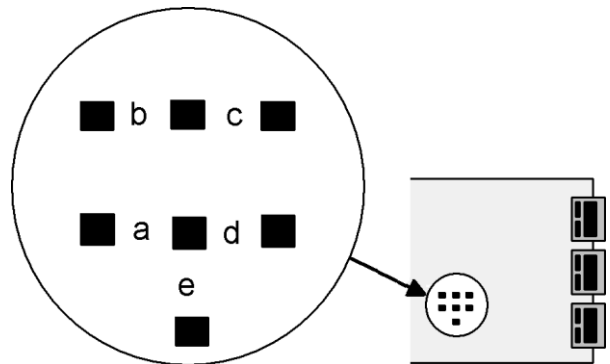

1. Use 2.5 mm (0.1") jumpers.
2. Store spare jumpers on an unused jumper post.

Example: Transmit weight in decimal tons and as 4-20 mA with overweight alarming

Application: Digitally transmit weight in metric tons with 3 decimal places using a 3 mV/V load cell. Also output weight from 0 to 5.000 tons as a 0-10V signal. Apply 10V excitation. At a load of 5.000 tons, the load cell output will be 30 mV. Alarm weight over 4.000 tons, but wait for 8 readings over this limit (or 15 msec) so as not to alarm on a noise spike.

The image shows three screenshots of a control panel interface, likely for a load cell or scale. The interface is divided into several tabs: Input+Display, Scaling, Filter, Relay Alarms, Communication, and Analog Out.

Input+Display Tab:

- Option Boards:** BASIC (selected), EXTENDED
- Sig Cond Option:** Load Cell
- Signal Input:**
 - Mode: Strain
 - Range: 50.0mV
 - Custom Curve: Disabled
 - Rate: Disabled
 - 50/60 Hz Line Freq: 60 Hz
- Display:**
 - Resolution: 4.5 Digits
 - Decimal Point: dd . ddd
 - Auto Tare: Disabled

Scaling Tab:

- Scale, Offset >** (selected): Scale = +.16667, Offset = +00.000
- Coordinates >** (selected): Low In = +00.000, Low Read = +00.000, High In = +30.000, High Read = +05.000
- Reading Coord >** (not selected)

Analog Out Tab:

- Analog Out Source:** Unfiltered
- Lo Range Reading:** +00.000
- Range:** 0-10V Voltage
- Hi Range Reading:** +05.000

Solution:

- Jumper signal conditioner for 50.000 mV range. Set power supply to 10V excitation.
- Under “Input+Display” tab, set Mode to Strain, range to 50.0mV, decimal point to 3 places, and “50/60 Hz Line Freq” to 60 Hz to reject 60 Hz noise.
- Under Scaling tab, if “Scale, Offset” method is selected, set Scale to 0.16667. The reason is that we want 30000 input counts to correspond to 5000 output counts.
- Under Scaling tab, if Coordinates is selected, set “High In” to 30.000 mV and “High Read” to 5.000 tons.
- Under “Relay Alarms” tab, enter 4.000 tons for Setpoint 1 and 8 readings to alarm.
- Under “Analog Out” tab, set Range to “0-10V Voltage”, “Lo Range Reading” to 0.000 tons and “Hi Range Reading” to 5.000 tons.

12. THERMOCOUPLE SIGNAL CONDITIONER BOARD

The thermocouple signal conditioner board can be configured via jumpers for either type J, K, E, N thermocouples or type T, R, S thermocouples, and for upscale or downscale open sensor indication. Instrument Setup Software recognizes the thermocouple board and will bring up the appropriate menu items for it; however, it does not recognize jumper settings. For each jumper selection, the thermocouple type, display in °C or °F, and resolution of 1°, 0.1° or 0.01° are software selectable. High resolution should only be used for relative readings, not absolute readings. Although available, 0.01° resolution is not recommended for thermocouples. Offset adjustment is available for thermocouples and is normally set to 0000.0. If °C is selected, entering an offset of 0273.2 will change the reading to Kelvin. If °F is selected, entering an offset of 0459.7 will change the reading to Rankin.

Board Revision A

Thermocouple Type	E4 Jumper
J, K, E, N	none
T, R, S	j
Open T/C Indication	E3 Jumper
Upscale	h
Downscale	i

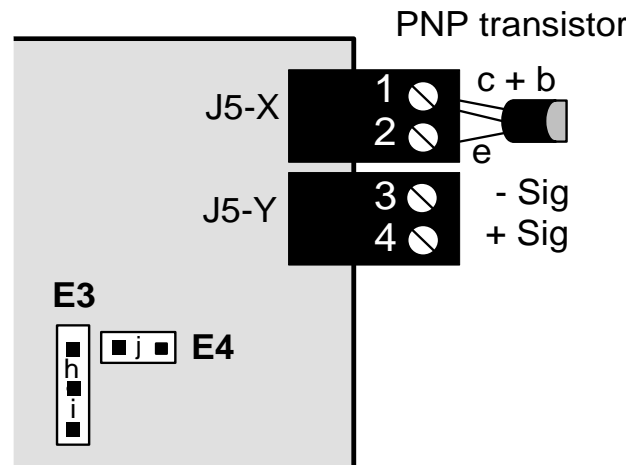

1. Use 2.5 mm (0.1") jumpers.
2. Store spare jumpers on an unused jumper post.

The largest source of thermocouple reading errors are variations in the alloys used in commercial thermocouple wires. Shown below are the American Limits of Error ASTM E230-ANSI MC 96.1. These are the error limits imposed on manufacturers of thermocouple wire, not error limits applicable to an instrument used with ideal thermocouple wire. The “Special Limit of Error” applies to more expensive “Special Limits of Error” (SLE) thermocouple wire.

Thermocouple Type	Temperature Range °C	Temperature Range °F	Standard Limit of Error	Special Limit of Error
J	0 to 750°C	32 to 1382°F	2.2°C or 0.75%	1.1°C or 0.4%
K	0 to 1250°C	32 to 2282°F	2.2°C or 0.75%	1.1°C or 0.4%
T	0 to 350°C	32 to 662°F	1.0°C or 0.75%	0.5°C or 0.4%
E	0 to 900°C	32 to 1652°F	1.7°C or 0.5%	1.0°C or 0.4%
N	0 to 1300°C	32 to 2372°F	2.2°C or 0.75%	1.1°C or 0.4%
S or R	0 to 1450°C	32 to 2642°F	1.5°C or 0.25%	0.6°C or 0.1%

Example: Transmit temperature, control a chiller, and provide an over-temperature alarm.

Application: Transmit temperature of a fermentation tank as a 4-20 mA signal from 15°C to 35°C. Turn on a chiller when the temperature reaches 28°C. Turn off the chiller when the temperature is below 24°C. Alarm temperatures over 30°C. The sensor is a Type K thermocouple.

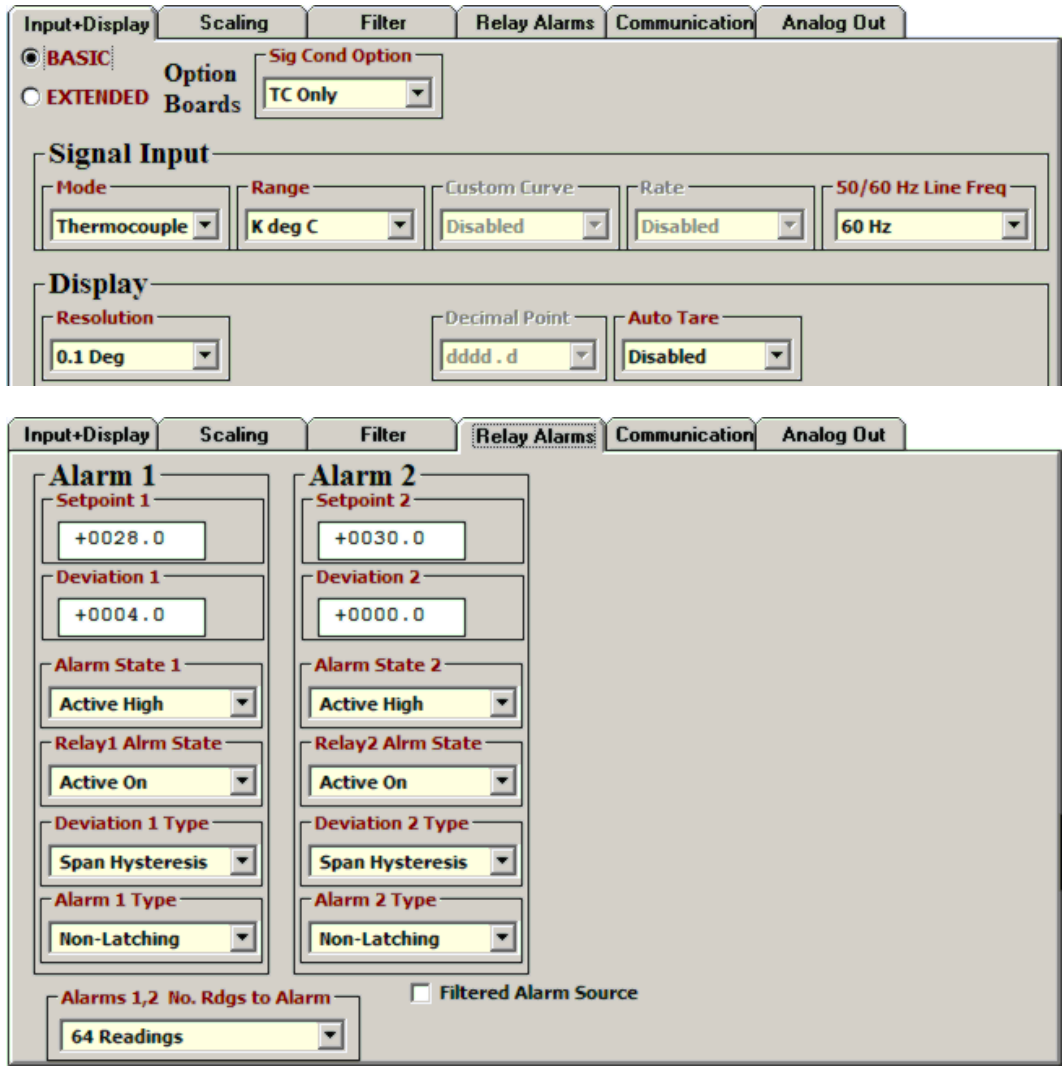

Solution:

- Jumper signal conditioner for Type K thermocouple.
- Under “Input+Display” tab, set Mode to Thermocouple, range to “K deg C”, Resolution to 0.1 deg, and “50/60 Hz Line Freq” to 60 Hz to reject 60 Hz noise.
- Under “Relay Alarms” tab, select “Span Hysteresis” with a setpoint of 28.0°C and a deviation of 4°C for Alarm 1, which will control the chiller. Select a setpoint of 30.0°C for Alarm 2, which will be used to alarm over-temperatures.
- Under “Analog Out” tab, set Range to “4-20mA Current”, “Lo Range Reading” to 15.0°C and “Hi Range Reading” to 35.0°C.

13. RTD & OHMS SIGNAL CONDITIONER BOARD

The same signal conditioner board can be configured via jumpers for four RTD types (DIN 100 Ω platinum, ANSI 100 Ω platinum, 120 Ω nickel, 10 Ω copper) or for five resistance ranges (from 20.000 Ω to 200.00 k Ω). Fixed 2 Ω or 2 M Ω resistance ranges can be provided by a factory modified signal conditioner board.

All ranges are factory calibrated with calibration factors stored in EEPROM on the signal conditioner board. Instrument Setup Software recognizes the board and will bring up the appropriate menu items for it; however, it does not recognize the jumper settings. Items to be entered in Instrument Setup Software for the input side include Mode (RTD or Ohms), Range (RTD type or ohms range), and Scale and Offset (a calibration correction applied to resistance).

Standard Board	Modified Board	E1 Jumper
Pt100, Ni120	N/A	a
Cu10, 20.000 Ω	0-2.0000 Ω	b
0 - 200.00 Ω	N/A	c
0 - 2.0000 k Ω	N/A	d
0 - 20.000 k Ω	N/A	e
0 - 200.00 k Ω	0 - 2.0000 M Ω	f
Connection for RTD or Resistance		E2 Jumper
2 or 4 wire		none
3 wire		g

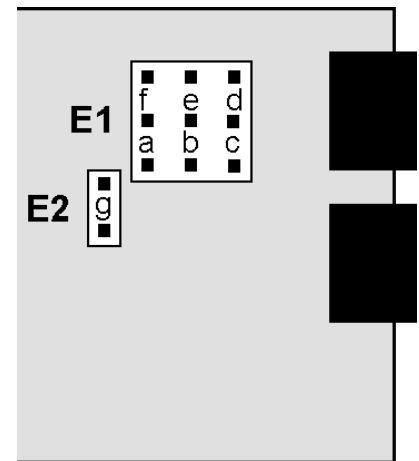

1. Use 2.5 mm (0.1") jumpers.
2. Store spare jumpers on an unused jumper post.

RTD and resistance measurement allow 2-, 3- or 4-wire hookup to compensate for lead wire resistance. Please see Section 6 for hookup diagrams.

- **In 2-wire hookup**, the transmitter senses the voltage drop across the load and both lead wires. The effect of the lead wires can be measured and subtracted by shorting out the load during transmitter setup, as prompted by Instrument Setup software. The short should be as close as possible to the load. Ambient temperature changes will still cause some error in the readings -- the higher the lead resistance, the greater the error.
- **In 3-wire hookup**, the transmitter automatically compensates for lead resistance by measuring the voltage drop in one current-carrying lead and assuming that the voltage drop in the other current-carrying lead is the same.
- **In 4-wire hookup**, there is no lead wire resistance error, as different pairs of wires are used for excitation and sensing. The sense wires only carry a few picoamperes and hence can measure the voltage across the RTD without error.

Example: Control incubator temperature, alarm over-temperatures, record on chart recorder

Application: Using an ANSI Platinum RTD as the sensor, control a heater to maintain the temperature of an incubator at $99.0 \pm 0.5^\circ\text{F}$. Use 4-wire connection. Output temperature to an analog chart recorder so that $0\text{V} = 95^\circ\text{F}$ and $10\text{V} = 105^\circ\text{F}$. Alarm temperatures of 102°F or higher.

The screenshot shows the 'Input+Display' configuration tab. It includes the following settings:

- Mode:** RTD
- Range:** ANSI deg F
- Resolution:** 0.1 Deg
- Signal Input:** Custom Curve: Disabled, Rate: Disabled, 50/60 Hz Line Freq: 60 Hz
- Display:** Decimal Point: dddd . d, Auto Tare: Disabled
- Input Connections:** 3,4 Wire
- A red rectangular area is present below the Resolution setting.
- A 'Read' button is located at the bottom center.

The screenshot shows the 'Relay Alarms' configuration tab with two alarm configurations:

Alarm 1	Alarm 2
Setpoint 1: +0099.0	Setpoint 2: +0102.0
Deviation 1: +0000.5	Deviation 2: +0000.0
Alarm State 1: Active High	Alarm State 2: Active High
Relay1 Alarm State: Active On	Relay2 Alarm State: Active On
Deviation 1 Type: Split Hysteresis	Deviation 2 Type: Band Deviation
Alarm 1 Type: Non-Latching	Alarm 2 Type: Non-Latching

At the bottom, there is a checkbox for 'Filtered Alarm Source' (unchecked) and a dropdown for 'Alarms 1,2 No. Rdgs to Alarm' set to '16 Readings'.

Solution:

- Jumper signal conditioner for Pt100 and 2 or 4-wire connection.
- Under “Input+Display” tab, set Mode to RTD, Range to “ANSI deg F”, Resolution to 0.1 deg, and “50/60 Hz Line Freq” to 60 Hz to reject 60 Hz noise.
- Under “Relay Alarms” tab, select “Split Hysteresis” with a setpoint of 99.0°F and a deviation of 0.5°F for Alarm 1, which will control the heater. Select a setpoint of 102.0°F for Alarm 2, which will be used to alarm over-temperatures.
- Under “Analog Out” tab, set Range to “0-10V Voltage”, “Lo Range Reading” to 95.0°F and “Hi Range Reading” to 105.0°F .

14. MAIN BOARD JUMPER SETTINGS

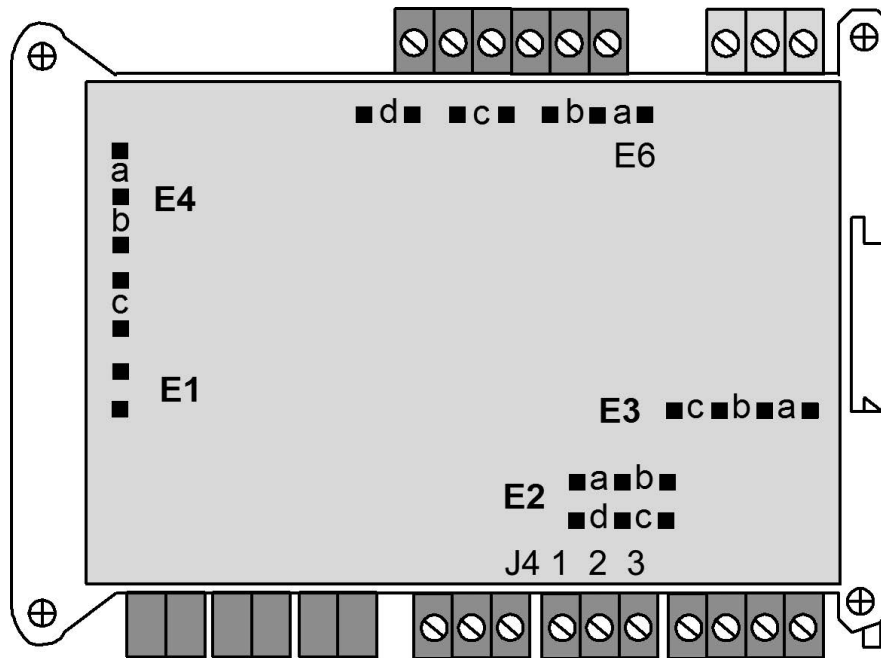

Serial Signal	Duplex	Jumpers	Termination Resistor*
RS485	Full	None	E6 a = Transmit, E6 c = Receive
	Half	E6 b + d**	E6 c
RS232	Full	None	None

* The termination resistor jumper settings should only be selected if the transmitter is the last device on an RS485 line longer than 200 feet (60 m).

** Or connect external BTX to BRX and ATX to ARX (same effect as internal jumpers).

To reset communications to 9600 baud, command mode, Custom ASCII protocol, and Address 1, place a jumper at E1, turn power on and off, remove the jumper, and restart the transmitter.

Analog Output	J4 Pins	Jumpers	Excitation Output	Jumpers
Current, 4-20 mA	1 Lo, 2 Hi	E2 a + d	5V, 100 mA	E3 a + c; E4 a
Voltage, 0-10V	1 Lo, 2 Hi	E2 b + c	10V, 120 mA	E3 a + c; E4 b + c
Voltage, -10V to +10V	3 Lo, 2 Hi	E2 b + c	12V, 140 mA	E3 a + c; E4 b
			24V, 50 mA	E3 b; E4 c

Notes: 1. Jumper settings are for main board Rev L.

2. Attempting to draw more than rated excitation output current will shut down the output.



3. **The analog output is sourcing.** Do not apply an external voltage. Applying an external voltage of 24 Vdc will burn out the transmitter main board.

15. DUAL RELAY OPERATION

Dual AC/DC solid state relays rated 120 mA are standard for alarm or setpoint control and are independently set up via the “Relay Alarms” tab of Instrument Setup Software. For online help with any data entry field, press the **F1** key.

The screenshot shows the 'Relay Alarms' configuration window. It has tabs for 'Input+Display', 'Scaling', 'Filter', 'Relay Alarms', 'Communication', and 'Analog Out'. The 'Relay Alarms' tab is active. It is divided into two columns: 'Alarm 1' and 'Alarm 2'. Each column has the following fields:

- Setpoint 1**: +0100.00
- Setpoint 2**: +020.000
- Deviation 1**: +0000.00
- Deviation 2**: +000.000
- Alarm 1 Source**: Item 1
- Alarm 2 Source**: Item 3
- Alarm 1 State**: Active High
- Alarm 2 State**: Active Low
- Relay1 Alarm State**: Active On
- Relay2 Alarm State**: Active Off
- Deviation 1 Type**: Band Deviation
- Deviation 2 Type**: Split Hysteresis
- Alarm 1 Type**: Non-Latching
- Alarm 2 Type**: Latching

At the bottom, there is a dropdown menu labeled 'Alarms 1,2 No. Rdgs to Alarm' with the value '4 Readings' selected.

- Setpoint.** The number to which the current reading is compared if deviation is set to zero. The reading is the count in engineering units that is transmitted digitally and is also used for analog output. For example, if the transmitted reading is in gallons/minute, the setpoint will be referenced to that reading, not to the raw pulse rate sent from a turbine flow meter.

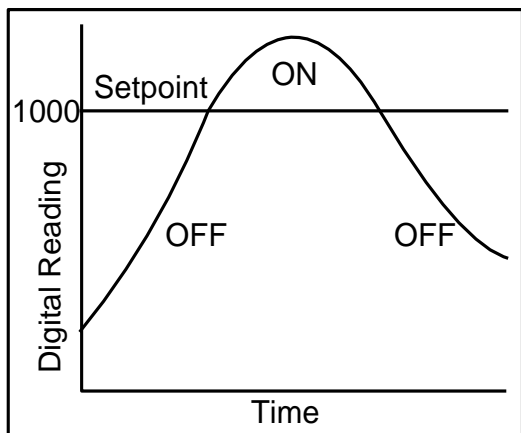

“Active High” On/Off setpoint control with deviation = 0

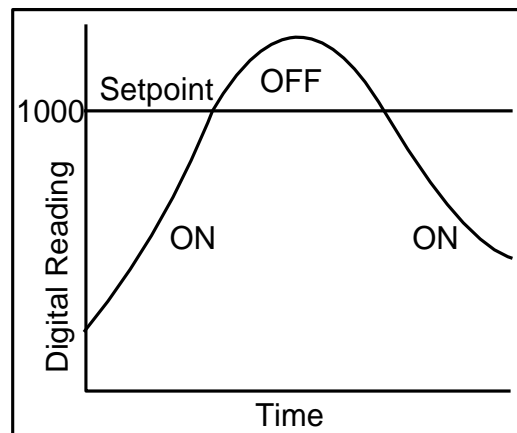

“Active Low” On/Off setpoint control with deviation = 0

- **Deviation.** A positive number that can be added or subtracted from the setpoint, depending on the Deviation Type, to determine when an alarm becomes Active or Inactive.
- **Alarm Source.** Depending on the Signal Input Mode and Function selected under the Input+ Display tab, the alarm can be assigned to any of up to three Items, for example to Item 1 (A rate / B rate), Item 2 (A rate), or Item 3 (B rate).
- **Alarm State.** If “Active High” is selected, the Active Alarm State is defined as being above the setpoint. If “Active Low” is selected, the Active Alarm State is defined as being below the setpoint. If “Disabled” is selected, the Alarm State is always inactive.
- **Relay State.** A setting with ties the Relay State to the Alarm State. If “Active On” is selected, the relay will be closed when the Alarm State is 1. If “Active Off” is selected, the relay will be open when the Alarm State is 1.
- **Deviation Type.** Three choices are offered: Split Hysteresis, Span Hysteresis, and Band Deviation. These define how Setpoint and Deviation are to be combined to set Alarm State.

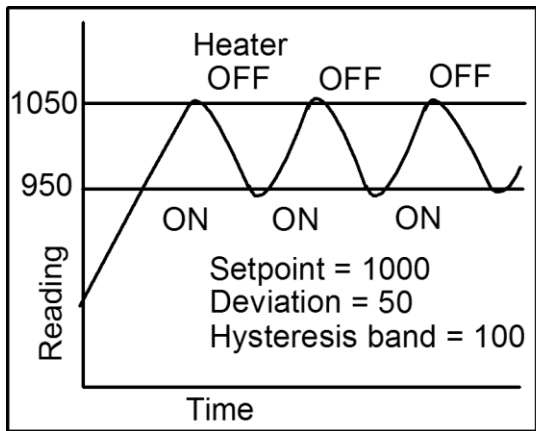

Span Hysteresis for heater control

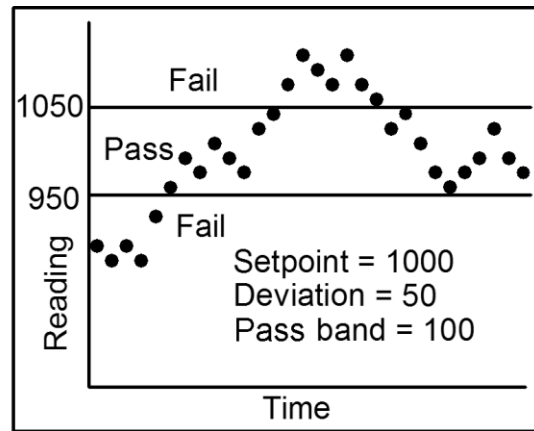

Band Deviation for component testing

In Split Hysteresis, the relay opens (or closes) when the reading goes above the Setpoint plus one Deviation, and closes (or opens) when the reading falls below the Setpoint less one Deviation. Two Deviation limits lie symmetrically around the Setpoint to create a deviation band. A narrow hysteresis band is often used to minimize relay chatter. A wide band can be used for on-off control.

In Span Hysteresis, operation is as for Split Hysteresis, except that the Setpoint is always on the high side, and a single Deviation lies below the Setpoint to create the hysteresis band. Span Hysteresis is considered by some to be more intuitive than Split Hysteresis.

In Band Deviation, the relay opens (or closes) when the reading falls within the deviation band, and closes (or opens) when the reading falls outside. Two deviation limits lie symmetrically around the setpoint to create the deviation band. Passbands around a setpoint are often used for go-no-go component testing.

- **Alarm Type.** Selections are Non-Latching and Latching. Under Non-Latching, the relay is only closed (or open) while the Alarm State is Active. Under Latching, the activated relay remains closed (or opens) until reset regardless of the Alarm State. Resetting is normally achieved by temporarily grounding one of the transmitter's control inputs, which has been set to Function Reset under the "Input+Display" tab.
- **Alarms 1,2 No. Rdgs to Alarm.** Selections are binary steps from 1 to 128. This is the number of consecutive alarm readings that must occur to create an Active alarm. Numbers higher than 2 provide some Alarm filtering so that 1 or 2 noisy readings do not cause an Active Alarm. The Alarm becomes Inactive if one of the consecutive readings fails to be an Alarm reading. The Alarm readings counter then resets to 0.

16. INPUT SIGNAL FILTERING

The **Filter tab** provides selections to minimize the effect time jitter and electrical noise which can affect trigger points. In most cases, filtering is only available for Item 1 and is grayed out for totalizing and stopwatch functions.



- **Time Constant** provides a moving average filter with the following eight equivalent RC time constants: no filter, 0.1 sec, 0.2 sec, 0.4 sec, 0.8 sec, 1.6 sec, 3.2 sec, and 6.4 sec. The longer time constants provide superior noise filtering at the expense of fast response time. Note that filtering can also be accomplished by lengthening the Gate time under the Input+Display tab.
- **Type** allows selection of Adaptive or Conventional filtering. With Adaptive, the time constant is changed dynamically so that the transmitter can respond rapidly to actual changes in signal while filtering out random noise. The moving average filter is reset to the latest reading when the accumulated difference between individual readings and the filtered reading exceeds a Threshold. The accumulated difference is also reset to zero when the latest reading has a different polarity than the filtered reading. With Conventional filtering, the adaptive feature is disabled and the Time Constant does not change.
- **Threshold** allows selection of Low Adaptive or High Adaptive for the Adaptive filter selection. Normally select Low. Select High if the signal has large spurious transients which should not be considered as an actual change in signal.
- **Peak/Valley Filter** allows the peak (maximum) or valley (minimum) functions to be based on Unfiltered or Filtered readings. Normally select Unfiltered. Select Filtered if you expect spurious readings which you do not wish to capture.

17. TRANSMITTER CALIBRATION

All analog input and analog output ranges of the transmitter have been digitally calibrated at the factory prior to shipment using calibration equipment certified to NIST standards. Calibration constants are stored digitally in non-volatile memory in EEPROM on the signal conditioner board and main board. This allows signal conditioner boards to be changed without requiring transmitter recalibration.

Recalibration is recommended every 12 months, the transmitter may be returned to the factory or to any authorized distributor. A modest fee will apply, which also covers a Calibration Certificate.

DC, load cell, AC RMS, and thermocouple signal conditioner boards can be calibrated using Instrument Setup Software running on a host PC, which is connected to the transmitter via RS232 or RS485. The Calibration screen of Instrument Setup Software is accessed by clicking on Calibration at the top of the DPM Main Menu screen. The PC first recognizes the type of board, then prompts you to apply specific jumpers and specific known signals for each range. Press Repeat to take more readings. When you have decided on which reading to accept, press on the number 1 through 10 of that reading.

The RTD/Ohms signal conditioner board cannot be calibrated using the Calibration screen of Instrument Setup Software. Instead, use the Scaling tab under Setup. Here you can enter values for Scale and Offset for a specific range. These corrections apply to resistance, not to RTD temperature. To calibrate RTD temperature, refer to the published resistance table for your RTD type, and calibrate resistance. For example, if your measured resistances are 0.1% low, apply a scale factor of 1.01.

18. CUSTOM CURVE LINEARIZATION

Curve.exe is a DOS-based, executable PC program used to set up an Extended transmitter so that the internal digital readings have a user-defined, non-linear relationship with the input signal. For example, it allows a transmitter to correct for transducer nonlinearity. Calculated linearizing parameters are downloaded from a PC into non-volatile memory of the transmitter. The curve-fitting algorithm uses quadratic segments of varying length and curvature, and includes diagnostics to estimate curve fitting errors. The program is self-prompting, avoiding the need for detailed printed instructions.

To get started, download **curve.exe** from our website into the directory that will also contain your data files, such as **c:\curves**. Connect your transmitter to the PC and double-click on **curve.exe**, which is an executable file. Follow the computer prompts and extensive help information. Pressing **R** (Enter) returns to the main menu. You will be given the choice of four data entry modes, which are explained in detail:

- 1) Text file entry mode
- 2) 2-coordinate keyboard entry mode
- 3) 2-coordinate file entry mode
- 4) Equation entry mode

19. MODBUS PROTOCOL TRANSMITTER COMMUNICATIONS

1.0 GENERAL

The Modbus capability conforms to the Modbus over Serial Line Specification & Implementation guide, V1.0. Both the Modbus RTU and Modbus ASCII protocols are implemented. This 5-page manual section presents key programmable Modbus features. Our detailed Modbus manual can be downloaded from <http://www.laurels.com/downloadfiles/modbus.pdf>

Modbus RTU

Baud Rate..... 300, 600, 1200, 2400, 4800, 9600 or 19200
Data Format 1 start bit, 8 data bits, 1 parity bit, 1 stop bit (11 bits total)
Parity..... None, Odd, Even (if None, then 2 Stop bits for 11 total)
Address..... 0 for broadcast, 1-247 for individual meters

Modbus ASCII

Baud Rate..... 300, 600, 1200, 2400, 4800, 9600 or 19200
Data Format 1 Start bit, 7 Data bits, 1 Parity bit, 1 Stop bit (10 bits total)
Parity..... None, Odd, Even (if None, then 2 Stop bits for 10 total)
Address..... 0 for broadcast, 1-247 for individual meters

2.0 FRAMING

Modbus RTU: Message frames are separated by a silent interval of at least 3.5 character times. If a silent interval of more than 1.5 character times occurs between two characters of the message frame, the message frame is considered incomplete and is discarded. Frame Check = 16 bit CRC of the complete message excluding CRC characters.

Modbus ASCII: The message begins immediately following a colon (:) and ends just before a Carriage Return/ Line Feed (CRLF). All message characters are hexadecimal 0-9, A-F (ASCII coded). The system allowable time interval between characters may be set to 1, 3, 5 or 10 seconds. Frame Check = 1 byte (2 hexadecimal characters) LRC of the message excluding the initial colon (:) and trailing LRC and CRLF characters.

3.0 ELECTRICAL INTERFACE

RS232, two-wire half-duplex RS485, or four-wire full-duplex RS485 signal levels are selectable via jumpers on the transmitter main board and a the connector. Please see Section 13. The RS485 selection provides a jumper selection for insertion of a line termination resistor. In case of a long line (greater than 500 ft) to the first device, a termination resistor should be selected for the first device. In case of a long line between the first and last devices, a termination resistor should be selected for the first and last devices. Never add termination resistors to more than two devices on the same line.

4.0 COMMUNICATIONS SETUP

Parameters selectable via downloaded Instrument Setup software:

Serial Protocol Custom ASCII, Modbus RTU, Modbus ASCII
 Modbus ASCII Gap Timeout..... 1 sec, 3 sec, 5 sec, 10 sec
 Baud Rate..... 300, 600, 1200, 2400, 4800, 9600, 19200
 Parity No parity, odd parity, even parity
 Device Address 0 to 247

5.0 SUPPORTED FUNCTION CODES

FC03: Read Holding Registers

Reads internal registers containing setup parameters (Scale, Offset, Setpoints, etc.)

FC10: Write Multiple Registers (FC10 = 16 dec)

Writes internal registers containing setup parameters (Scale, Offset, Setpoints, etc.)

FC04: Read Input Registers

Reads measurement values and alarm status. Returns values in 2's Complement Binary Hex format without a decimal point. The displayed system decimal point can be read with FC03 at address 0057. Use only **odd** Register Addresses and an **even** number of Registers.

Register Address	TM Transmitter Response
00 01	Returns Hi word of Alarm status
00 02	Returns Lo word of Alarm status
00 03	Returns Hi word of Measurement value
00 04	Returns Lo word of Measurement value
00 05	Returns Hi word of Peak value
00 06	Returns Lo word of Peak value
00 07	Returns Hi word of Valley value
00 08	Returns Lo word of Valley value

FC05: Write Single Coil

Action command to meter

Output Address	Output Value	Action Command
00 01	FF 00	Transmitter Reset (No Response)
00 02	FF 00	Function Reset (Peak, Valley)
00 03	FF 00	Latched Alarm Reset
00 04	FF 00	Peak Reset
00 05	FF 00	Valley Reset
00 0C	FF 00	Tare Command (Weight Transmitter) (00 00 resets Tare)

FC08: Diagnostics

Checks communications between the Master and Slave, and returns the count in the Modbus Slave counters (which are reset when the meter is reset).

Hex Sub Function Code	Data Send	Response Data	Description
00 00	Any	Same as sent	Returns Query Data (N x 2 bytes). Echo Request.
00 01	FF 00 00 00	FF 00 00 00	Restarts Communications. If in the Listen-Only mode, no response occurs. Takes Slave out of the Listen-Only mode and one of the following: Clears communications event counters. Does not clear communications event counters.
00 04	00 00	None	Forces Listen-Only. All addressed and broadcast Messages are monitored and counters are incremented, but no action is taken or response sent. Only Sub-Function 00 01 causes removal of this Listen-Only state.
00 0A	00 00	00 00	Clears all Modbus slave counters.
00 0B	00 00	Total Message Count	Returns total number of messages detected on the bus, including those not addressed to this Slave. Excludes bad LRC/CRC, parity error or length < 3.
00 0C	00 00	Checksum Error Count	Returns total number of messages with bad LRC/ CRC, parity or length < 3 errors detected on the bus including those not addressed to the Slave.
00 0D	00 00	Exception Error Count	Returns total number of Exception responses returned by the Addressed Slave or that would have been returned if not a broadcast message or if the Slave was not in a Listen-Only mode.
00 0E	00 00	Slave Message Count	Returns total number of messages, either broadcast or addressed to the Slave. Excludes bad LRC/CRC, parity or length < 3 errors.
00 0F	00 00	No Response Count	Returns total number of messages, either broadcast or addressed to the Slave, for which Slave has returned No Response, neither a normal response nor an exception response. Excludes bad LRC/CRC, parity or length < 3 errors.
00 11	00 00	Slave Busy	Returns total number of Exception Code 6 (Slave Busy) responses.

6.0 SUPPORTED EXCEPTION RESPONSE CODES

Code	Name	Error Description
01	Illegal Function	Illegal Function Code for this Slave. Only hex Function Codes 03, 04, 05, 08, 10 (dec 16) are allowed.
02	Illegal Data Address	Illegal Register Address for this Slave.
03	Illegal Data Value	Illegal data value or data length for the Modbus protocol.
04	Slave Device Failure	Slave device failure (eg. Transmitter set for external gate).

7.0 MESSAGE FORMATTING

MA = Meter Address	DD = Data (Hex)	CL = CRC Lo Byte
FC = Function Code	WW = Data (On/Off)	CH = CRC Hi Byte
RA = Register Address	SF = Sub-Function	CR = Carriage Return
NR = Number of Registers	EC = Error Code	LF = Line Feed
NB = Number of bytes	LRC = ASCII Checksum	

Modbus RTU Format

FC	Action	> 3.5 Char	Byte Number										
			1	2	3	4	5	6	7	8	9	10	11
03	Request	NoTx	MA	FC	RA	RA	NR	NR	CL	CH			
03	Response	NoTx	MA	FC	NB	DD*	DD*	CL	CH				
04	Request	NoTx	MA	FC	RA	RA	NR	NR	CL	CH			
04	Response	NoTx	MA	FC	NB	DD*	DD*	CL	CH				
05	Request	NoTx	MA	FC	RA	RA	WW	WW	CL	CH			
05	Response	NoTx	MA	FC	RA	RA	WW	WW	CL	CH			
08	Request	NoTx	MA	FC	SF	SF	WW	WW	CL	CH			
08	Response	NoTx	MA	FC	SF	SF	DD	DD	CL	CH			
10	Request	NoTx	MA	FC	RA	RA	NR	NR	NB	DD*	DD*	CL	CH
10	Response	NoTx	MA	FC	RA	RA	NR	NR	CL	CH			
	Exception Response	NoTx	MA	FC +80	EC	CL	CH						

DD* = (DD DD) times NR (Number of Registers)

Modbus ASCII Format

FC	Action	Byte Number												
		1	2	3	4	5	6	7	8	9	10	11	12	13
03	Request	:	MA	FC	RA	RA	NR	NR	LRC	CR	LF			
03	Response	:	MA	FC	NB	DD*	DD*	LRC	CR	LF				
04	Request	:	MA	FC	RA	RA	NR	NR	LRC	CR	LF			
04	Response	:	MA	FC	NB	DD*	DD*	LRC	CR	LF				
05	Request	:	MA	FC	RA	RA	WW	WW	LRC	CR	LF			
05	Response	:	MA	FC	RA	RA	WW	WW	LRC	CR	LF			
08	Request	:	MA	FC	SF	SF	WW	WW	LRC	CR	LF			
08	Response	:	MA	FC	SF	SF	DD	DD	LRC	CR	LF			
10	Request	:	MA	FC	RA	RA	NR	NR	NB	DD*	DD*	LRC	CR	LF
10	Response	:	MA	FC	RA	RA	NR	NR	LRC	CR	LF			
Exception Response		:	MA	FC +80	EC	LRC	CR	LF						

DD* = (DD DD) times NR (Number of Registers)

8.0 MESSAGE EXAMPLES

All examples are for Transmitter Address = 01 and No Parity.

Ser_4 -> Addr ->	Action	Modbus RTU 010 001	Modbus ASCII 020 001
Restart Com- munications	Request Response*	010800010000B1CB 010800010000B1CB	:010800010000F6crlf :010800010000F6crlf
Meter Reset	Request Response	01050001FF00DDFA None	:01050001FF00FAcrlf None
Digital Reading ** ***	Request Response	01040003000281CB 010404000009D67C4A	:010400030002F6crlf :010404000009D618crlf
Write Setpoint 1 = +37.00***	Request Response	0110000100020400000E743624 01030400000E74FE74	:0110000100020400000E7466crlf :011000010002ECcrlf
Read Setpoint 1 = +37.00***	Request Response	01030001000295CB 01030400000E74FE74	:010300010002F9crlf :01030400000E7476crlf

* Suggested as first message after power-up. If transmitter is in Listen-Only mode, no response is returned. ** Example while reading +25.18 *** Decimal point is ignored.

9.0 INTERNAL REGISTERS: Please refer to the full Modbus Protocol Communications Manual, which is downloadable from our website.

20. CUSTOM ASCII PROTOCOL TRANSMITTER COMMUNICATIONS

1.0 SERIAL COMMUNICATION FORMAT

Mode Full Duplex (Separate transmit and receive lines) and Half Duplex (RS485 only)
Baud Rate 300, 600, 1200, 2400, 4800, 9600, 19200 selectable with Instrument Setup software.
Parity None
Word length..... 8 data bits
Stop bit 1

The Custom ASCII protocol is simpler than the Modbus protocol. This 5-page manual section provides some of its key programmable features. Our detailed Serial Communications manual can be downloaded from <http://www.laurels.com/downloadfiles/serialcom2.pdf>

2.0 MEASUREMENT DATA FORMAT

The basic measurement data format consists of 8 ASCII characters for analog input “DPM” transmitters, such as +999.99<CR>, where <CR> is the carriage return character. The first character is always a plus or minus sign. A decimal point is always furnished, even when it follows the last digit.

Adding a Line Feed Character to the Basic Format: Printers and other devices that receive the data may require a line feed character <LF> following the <CR>. The line feed character <LF> may be selected using Instrument Setup software.

Adding a Coded Data Character to the Basic Format: A coded character from A to H may be added to the data string according to the table below to indicate the alarm and overload status of the device. If used, this character precedes the <CR>, so that it is the last printable character in the string. With the optional <LF> and coded character selected, the data string will consist of 10 characters for analog input “DPM” transmitters, such as +999.99A<CR><LF>.

Alarm Status	No Overload	Overload
Neither Alarm set	A	E
Alarm 1 set only	B	F
Alarm 2 set only	C	G
Both Alarms set	D	H

For example, a coded character “G” indicates that Alarm 2 only is set and that the transmitter is in the overload condition. This information is useful when data is supplied to a computer for listing and analysis, or when data is supplied to a Remote Display in a Master-Slave configuration.

Values are transmitted in a continuous string with no intervening spaces. If the 5th digit in is set to 1 using Instrument Setup software, the termination characters of <CR> and optional <LF> appear after each value. If the 5th digit is set to 0, the termination characters appear only once at the end of the string. In either case, if included, the coded character appears at the end of the last value only.

3.0 NETWORK CONFIGURATIONS

Using the Custom ASCII protocol, TM Series transmitters can operate in a point-to-point mode using RS232 or RS485, or in a multi-point mode using RS485.

The point-to-point mode is a direct connection between a computer (or other digital device) and the transmitter. Any device address can be selected; however, it is suggested that address 1 be selected as a standard for the point-to-point mode.

The multi-point mode is a connection from a host computer to a multiplicity of transmitters bused together with their inputs and outputs connected in parallel. For long cable runs, the last device should have a termination resistor installed. It is necessary to set up each device on the bus with a different address from 1 to 31. To command a particular device, its address is used in conjunction with the command, and only that device responds. The outputs of all of the devices on the bus are set to a high impedance state, except the device being addressed. The device addresses range from 1 to 31, with 0 being a special address to which a meter responds only internally (e.g. Reset), but does not transmit any response on the output lines. All devices may be commanded simultaneously with a 0 address, and there will not be any output response contention. Addressing of transmitters can be set with Instrument Setup software.

4.0 COMMAND MODE OVERVIEW

Using the Custom ASCII protocol, TM Series transmitters operate in the Command Mode only. In this mode, the device does not send data automatically, but responds to commands received from a host computer. These commands can be:

- To transmit the latest or peak measurement
- To reset the meter completely or just the peak value and/or latched alarms
- To display a value sent from the computer
- To transmit present setup parameters
- To receive new setup parameters,
- To monitor or alter data in selected memory locations of the meter.

5.0 COMMAND MODE FORMAT

CHAR 1 - Command Identifier

All commands begin with "*" followed by the meter address, then a command letter followed by a sub-command number or letter. Additional characters may be appended. All commands terminate with <CR> (<LF> ignored).

Peak value reset	*1C3
Remote display reset	*1C4
Valley reset	*1C9
Tare function	*1CA
Tare reset	*1CB

6.0 READING AND WRITING TO RAM AND NONVOLATILE MEMORY

CHAR 1, 2: The Recognition character and Meter Address Code are the same as shown in previous table.

CHAR 3: Command character:

G	Read bytes from RAM Memory
F	Write bytes to RAM Memory (DPM and Scale meter only)
R	Read bytes from Upper RAM Memory
Q	Write bytes to Upper RAM Memory
X	Read words from Non-Volatile Memory
W	Write words to Non-Volatile Memory

CHAR 4: Command character. Sub-command. Number of Bytes of RAM or Words (2 Bytes) of non-volatile memory data being transferred.

Code #	Number	Code #	Number	Code #	Number
1	1	B	11	L	21
2	2	C	12	M	22
3	3	D	13	N	23
4	4	E	14	O	24
5	5	F	15	P	25
6	6	G	16	Q	26
7	7	H	17	R	27
8	8	I	18	S	28
9	9	J	19	T	29
A	10	K	20	U	30

CHAR 5, 6: See tables for the RAM MEMORY ADDRESSES and NONVOLATILE MEMORY ADDRESSES with their respective data definitions.

General, Reading and Writing Ram Memory Data

RAM memory data is read and written as a continuous string of bytes consisting of 2 hex characters (0-9,A-F) per byte. Included in the command are the total number of bytes to be transferred and the most significant address in RAM of the continuous string of bytes. The format is:

Read lower RAM data	*1Gnaa
Write lower RAM data	*1Fnaa<data>
Read upper RAM data	*1Rnaa
Write upper RAM data	*1Qnaa<data>

where: n is the number of bytes to be read or written.
aa is the most significant address in RAM of the bytes to be read or written.
<data> is n bytes of 2 hex characters per byte in order from the most to the least significant byte.

The number of bytes n consists of a single code character representing values from 1 to 30 as shown above under CHARACTER 4. The most significant address aa consists of 2 hex characters as shown below under RAM MEMORY ADDRESSES AND DATA DEFINITIONS.

General, Reading and Writing Nonvolatile Memory Data

Nonvolatile data is read and written as a continuous string of words consisting of 2 bytes or 4 hex characters (0-9,A-F) per word. Included in the command is the total number of words to be transferred and the most significant address in nonvolatile memory of the continuous string of words. The format is:

Read nonvolatile memory data	*1Xnaa (followed by Meter reset)
Write non-volatile memory data	*1Wnaa <data> (followed by Meter reset)

where: n is the number of words to be read or written.
aa is the most significant address in nonvolatile memory of the words to be read or written.
<data> is n words of 2 bytes or 4 hex characters per word in order from the most to the least significant address.

The coded number of words n consists of a single character representing values from 1 to 30 as shown under CHARACTER 4. The most significant address aa consists of 2 hex characters as shown under NONVOLATILE MEMORY ADDRESSES.

21. LT SERIES ANALOG INPUT TRANSMITTER SPECIFICATIONS

Mechanical

Case dimensions.....	120 x 101 x 22.5 mm
Case mounting.....	35 mm DIN rail per EN 50022
Electrical connections.....	Detachable screw plug connectors

Environmental

Operating temperature.....	-40°C to 70°C
Storage temperature.....	-40°C to 85°C
Relative humidity.....	95% from 0°C to 40°C, non-condensing

Power & Electrical

Power to Transmitter.....	85-264 Vac / 90-300 Vdc, or 12-32 Vac / 10-48 Vdc
Power Isolation.....	250 Vrms between power, signal input, analog output, relays, and serial I/O

Transmitter Setup

Selection of signal ranges & temperature sensors.....	Jumpers on signal conditioner board
Selection of serial format, excitation output, analog output.....	Jumpers on main board
Programming.....	Via PC using Instrument Setup software and serial cable

Analog to Digital Conversion)

Conversion rate.....	60/sec at 60 Hz power, 50/sec at 50 Hz power
Input resolution.....	16 bits (65,536 steps)

Analog Output (standard)

Output Levels.....	4-20 mA, 0-20 mA, 0-10V, -10V to +10V
Source of sink.....	Sourcing. Do not connect to a load which applies a voltage.
Compliance at 20 mA.....	10V (0 to 500Ω load)
Compliance at 10V.....	2 mA (5 kΩ load or higher)
Output resolution.....	16 bits (65,536 steps)
Output accuracy.....	±0.02% of full span for DC inputs, ±0.1% for AC RMS inputs

Serial I/O (standard)

Serial formats.....	RS232 or RS485 (half or full duplex), selectable
Serial protocol.....	Custom ASCII or Modbus (RTU or ASCII)
Serial connector.....	Detachable screw terminal plugs

Transducer Excitation Output (standard for DC, process, strain gauge, load cell inputs)

Output Isolation.....	± 50 Vdc to meter ground
Selectable levels.....	5 Vdc ± 5%, 100 mA; 10 Vdc ± 5%, 120 mA; 12 Vdc ± 5%, 140 mA; 24 Vdc ± 5%, 50 mA

Dual Relay Output (standard)

Relay type.....	Two solid state relays, SPST, normally open, Form A
Load rating.....	120 mA at 140 Vac or 180 Vdc

Input Signal Noise Rejection

CMV, DC to 60 Hz250V RMS
 CMR, DC to 60 Hz 130 dB
 NMR at 50/60 Hz 90 dB with no digital filtering
 Input filtering Programmable digital time constants from 80 ms to 9.6 s

Overvoltage Protection

Voltage input ranges of 2V and above (AC or DC) 600 Vrms
 Voltage input ranges of 200 mV (AC or DC), load cell, thermocouple, RTD 100 Vrms

DC Volts, DC Amps, Process and DC Ratio Input

Range	Input Resistance	Input Error
±200.00 mV ±2.0000 V ±20.000 V ±200.00 V	1 GΩ 1 GΩ 10 MΩ 10 MΩ	0.01% of full scale ± 2 counts
±300.0 V & ±600.0 V*	10 MΩ	±0.4 V
±2.0000 mA ±20.000 mA ±200.00 mA	100 Ω 10 Ω 1 Ω	0.01% of full scale ± 2 counts
±5.000 A	0.01 Ω	±10 mA

True AC RMS Volts & Amps

Range	Input Resistance	Input Error
200.00 mV 2.0000 V 20.000 V 200.00 V	1 MΩ 1 MΩ 1 MΩ 1 MΩ	0.03% of full scale ± 2 counts
300.0 V & 600.0 V*	1 MΩ	±0.8 V
2.0000 mA 0.000 mA 200.00 mA	100 Ω 10 Ω 1 Ω	0.03% of full scale ± 2 counts
5.000 A	0.01 Ω	±20 mA

Coupling AC or AC + DC (jumper selectable)
 AC Frequency Range 10 Hz to 15 kHz, crest factor to 3.0

* 600V ranges are only ETL certified to 300V.

Load Cell, Strain Gauge & Microvolt Input

Range	1 Count	Input Resistance	Input Error
±20.000 mV	1 µV	1 GΩ	0.01% of full scale ± 2 counts for absolute voltage readings 0.01% of reading ± 2 counts for ratiometric bridge readings
±50.000 mV	1 µV		
±100.00 mV	10 µV		
±250.00 mV	10 µV		
±500.00 mV	10 µV		

RTD Input (1°, 0.1° or 0.01° resolution)

Type	Excitation	Range	Conformity Error
Platinum, Pt100 α = .00385 (DIN)	256 µA	-202 to 850°C -331 to 1562°F	0.03°C 0.05°F
Platinum, Pt100 α = .003925 (ANSI)	256 µA	-202 to 631°C -331 to 1168°F	0.04°C 0.07°F
Nickel, Ni120 α = .00672	256 µA	-80°C to +260°C -112°F to +500°F	±0.05°C ±0.09°F
Copper, Cu10 α = .00427	5.0 mA	-97°C to +260°C -143°F to +500°F	±0.05°C ±0.09°F

RTD connection:2, 3 or 4 wire
 Span tempco..... ±0.003% of reading/°C
 Zero tempco ±0.03 deg/deg
 Sensor lead resistance tempco per conductor, 2-wire..... 10 µdeg / Ω / deg up to 10 Ω
 Sensor lead resistance tempco per conductor, 3 & 4-wire 10 µdeg / Ω / deg up to 100 Ω
 Over-voltage protection 125 Vac
 Open sensor indication 0 mA or > 20 mA output, jumper selectable

Thermocouple Input (1° or 0.1° resolution)

Selection of signal ranges & temperature sensorsVia jumpers and software
 Selection of serial format, excitation output, analog output..... Via jumpers on main board
 Programming..... Via PC using Instrument Setup software and serial cable
 Input resistance 1 GΩ
 Overall input accuracy ± 0.01% of full span ±2 counts
 Max lead resistance 1 kΩ max for rated accuracy
 Span tempco..... ±0.003% of reading/°C
 Reference junction tempco ±0.02 deg/deg
 Over-voltage protection 125 Vac
 Open sensor indication 0 mA or > 20 mA output, jumper selectable

Type	Range	Conformity Error
J	-210 to 760°C -347to 1400°F	0.09°C 0.16°F
K	-244 to 1372°C -408to 2501°F	0.10°C 0.17°F
T	0 to 400°C -257 to 0°C 32 to 752°F -430 to 32°F	0.03°C 0.20°C 0.05°F 0.36°F
E	-240 to 1000°C -400 to 1830°F	0.18°C 0.32°F
N	-245 to 1300°C -410 to 2370°F	0.10°C 0.17°F
S	-46 to +68°C -51 to +213°F	0.12°C 0.22°F
R	-45 to 1768°C -49 to 3214°F	0.17°C 0.31°F

Resistance Input

Range	1 Count	Excitation	Input Error
0-20.000 Ω	1 mΩ	5 mA	0.01% of reading ± 2 counts
0-200.00 Ω	10 mΩ	500 μA	
0-2000.0 Ω	100 mΩ	50 μA	
0-20000 Ω	1 Ω	5 μA	
0-200.00 kΩ	10 Ω	500 nA	
0-2.0000 MΩ*	100 Ω	500 nA	

* Factory special fixed range

Load connection:2, 3 or 4 wire
Span tempco.....±0.003% of reading/°C
Over-voltage protection 125 Vac
Open sensor indication0 mA or > 20 mA output, jumper selectable

22. WARRANTY

Laurel Electronics Inc. warrants its products against defects in materials or workmanship for a period of three years from the date of purchase.

In the event of a defect during the warranty period, the defective unit may be returned to the seller, which may be Laurel or a Laurel distributor. The seller may then repair or replace the defective unit at its option. In the event of such a return, freight charges from the buyer shall be paid by the buyer, and freight charges from the seller shall be paid by the seller.

LIMITATION OF WARRANTY

The foregoing warranty shall not apply to defects resulting from:

1. Improper installation or miswiring.
2. Improper or inadequate maintenance.
3. Unauthorized modification or misuse.
4. Operation outside the environmental specifications.
5. Mishandling or abuse.

The warranty set forth above is exclusive and no other warranty, whether written or oral, is expressed or implied. Laurel specifically disclaims implied warranties of merchantability and fitness for a particular purpose.

Any electronic product may fail or malfunction over time. To minimize risks associated with reliance on Laurel products, users are expected to provide adequate system-level design and operating safeguards. Laurel's products are intended for general purpose industrial or laboratory use. They are not intended nor certified for use in life-critical medical, nuclear, or aerospace applications, or for use in hazardous locations.

EXCLUSIVE REMEDIES

The remedies provided herein are Buyer's sole and exclusive remedies. In no event shall Laurel be liable for direct, indirect, incidental or consequential damages (including loss of profits) whether based on contract, tort, or any other legal theory.