

# QLS Quad Output 4-20 mA Current Loop Splitter / Retransmitter

With  $\pm 10V$  common mode isolation  
between input & outputs

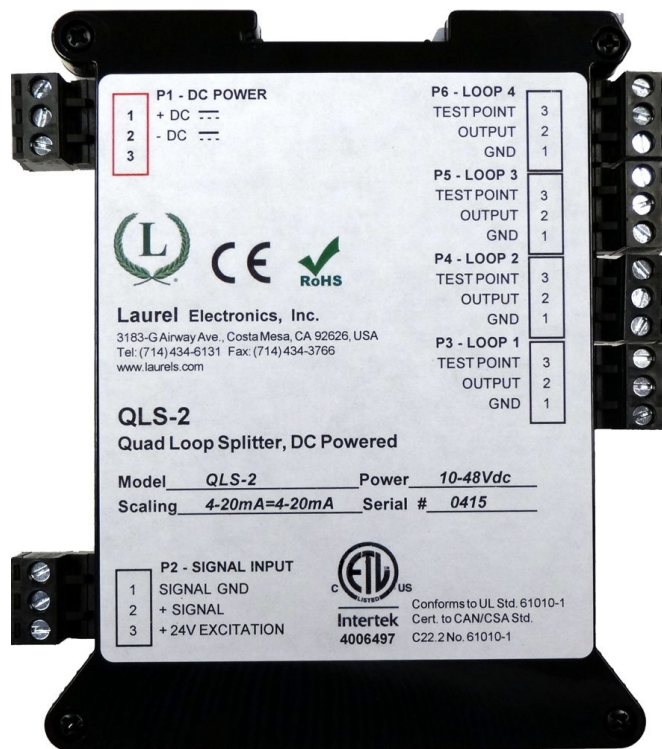

**LAUREL Electronics Inc.**

3183-G Airway Ave, Costa Mesa, CA, 92626, USA

Tel: (714) 434-6131 Fax: (714) 434-3766 Website: [www.laurels.com](http://www.laurels.com)



## 1. ORDERING GUIDE

- QLS-1** Quad isolated output loop splitter/ retransmitter, 85-264 Vac power.
- QLS-2** Quad isolated output loop splitter/ retransmitter, 10-48 Vdc or 12-32 Vac power.

## 3. PRODUCT DESCRIPTION

**Model QLS** sources up to four (4) independently adjustable 4-20 mA outputs from a single input, which can be 4-20 mA, 1-5V, 0-5V or 0-10V, as selected by jumpers. The outputs can share a common ground. The input and outputs are mutually isolated to +10V / -20V at 600 ohm load by means of active circuitry to accommodate differences in local grounds. If any device in an output loop is removed from the loop or fails, or if a wiring fault occurs, the other loops continue to operate properly. Each loop only drives a single load, avoiding compliance problems.

**Model QLS** overcomes problems of simply placing loads in series in a single 4-20 mA loop. In such a configuration, the devices in the loop cannot share a common ground, but must be electrically floating, which is often not possible. When any device in a single loop is removed, fails or if a wiring fault occurs, all other devices in the loop lose their 4-20 mA signal. The transmitter voltage compliance limit may be exceeded, since the voltage drops across loads in series are additive. Also, the 4-20 mA signal to each load device cannot be individually adjusted for calibration purposes.

**Power** for the loop splitter can be 85-264 Vac (Model QLS-1) or low voltage 10-48 Vdc or 12-32 Vac (Model QLS-2). An excitation output is provided on the signal input side to drive a 2- or 3-wire transmitter at 24 Vdc and up to 30 mA.

**Each output loop** provides two potentiometers for  $\pm 10\%$  fine adjustment of zero and span, a yellow LED lamp to indicate loop continuity, and a current test point across a 10-ohm series resistor, where 200 mV corresponds to 20 mA. This allows a multimeter to be used to measure the loop current without breaking the loop.





## 4. RECEIVING & UNPACKING

Your QLS loop splitter / retransmitter was carefully tested and inspected prior to shipment. Should the unit be damaged in shipment, notify the freight carrier immediately. Inspect the label on the unit for the type of input power: QLS-1 for 85-264 Vac power, or QLS-2 for 10-48 Vdc or 12-32 Vac power. In the event the unit is not as ordered or is inoperable, return it to the place of purchase for repair or replacement. Please include a description of the problem.







## 5. SAFETY CONSIDERATIONS

**Warning:** Use of this unit in a manner other than specified in this manual may impair the protection of the unit and subject the user to a hazard. Do not attempt to operate if the unit shows visible damage.

### Cautions:

-  This unit may be powered from 85-264 Vac with the worldwide voltage power supply (Model QLS-1) or from 12-30 Vac or 10-48 Vdc (Model QLS-2). Verify that you have the proper model for the power to be used.
-  The 85-264 Vac power connector (P1 Pins 1-3) is colored **Green** to differentiate it from other input and output connectors. The 12-30 Vac or 10-48 Vdc power connector is colored **Black**. This unit has no power switch. It will be in operation as soon as power is applied.
-  To avoid dangers of electrocution and/or short circuit, do not attempt to open the case while the unit is under power
-  To prevent an electrical or fire hazard, do not expose the unit to excessive moisture. Do not operate the unit in the presence of flammable gases or fumes, as such an environment constitutes an explosion hazard.

### Symbols used:

- |   |   |   |                                      |
|---|---|---|--------------------------------------|
|  | Caution (refer to accompanying documents)                                     |  | Earth ground                         |
|  | Caution, risk of electric shock   |  | Signal or loop ground                |
|  | Equipment protected throughout by double insulation or reinforced insulation. |  | Both direct and alternating current. |

### Operating environment:

-  Class II (double insulated) equipment designed for use in Pollution degree 2.

## 6. JUMPER SETTINGS

The four outputs are always 4-20 mA process loops. The signal input can be 4-20 mA, 1-5V, 0-5V or 0-10V, as set by jumpers adjacent to the signal input connector on the circuit board. The factory default input setting is 4-20 mA. To change jumpers, remove power, then open the case by removing the screws at the four corners of the case. Store the unused jumper, if any, on an unused pin.

### Jumper Positions:

4-20 mA .....	<b>a + c</b>
1-5V .....	<b>d</b>
0-5V .....	<b>b + f</b>
0-10V .....	<b>a + e</b>

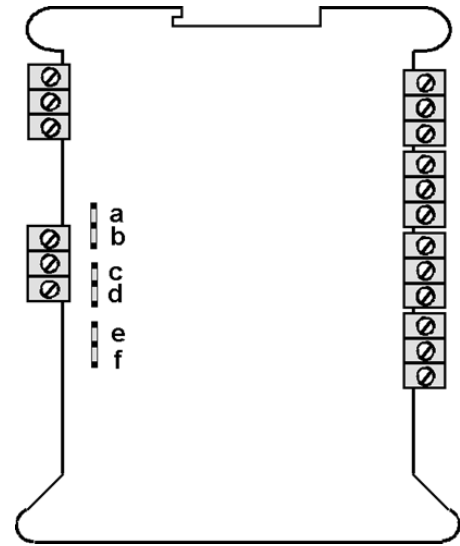

## 7. ELECTRICAL CONNECTIONS

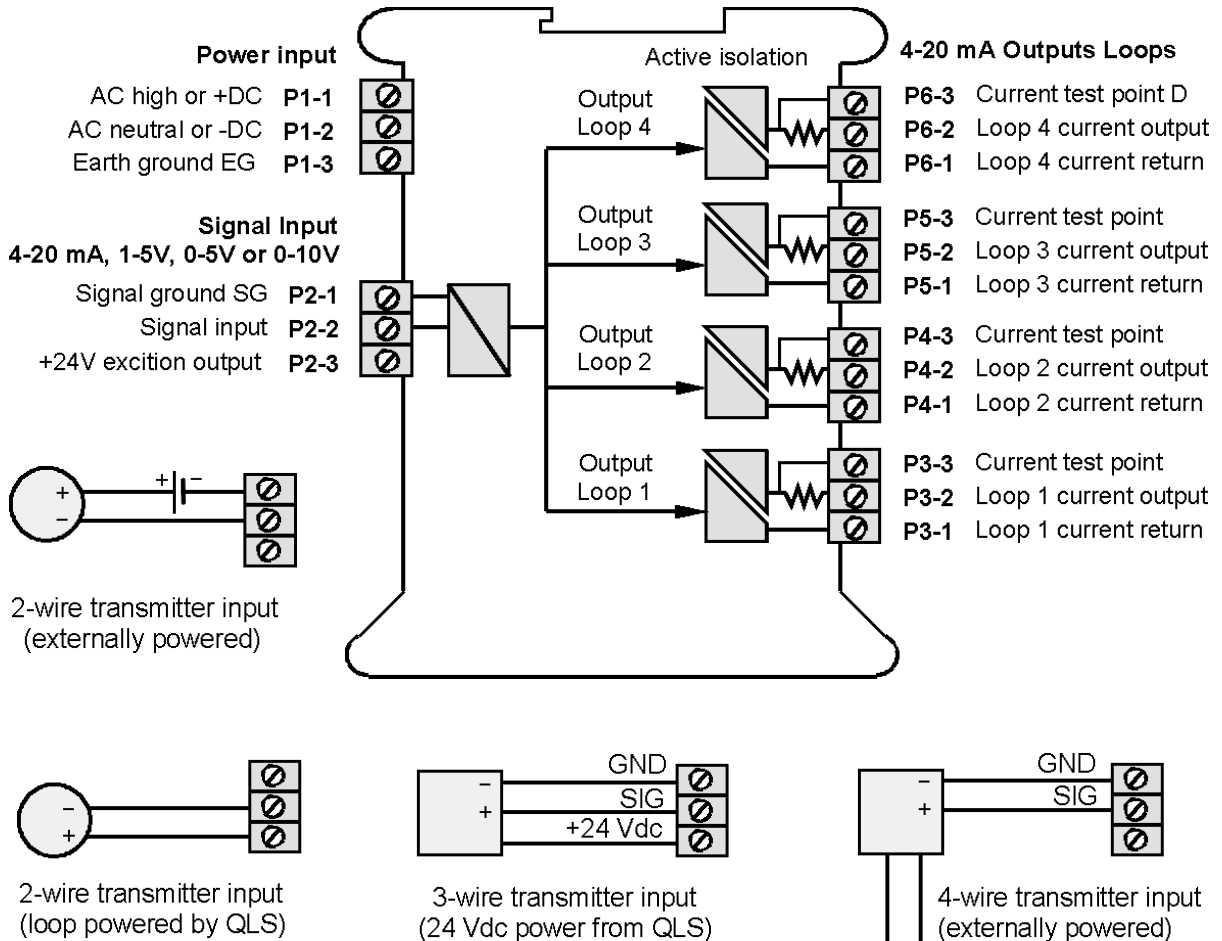

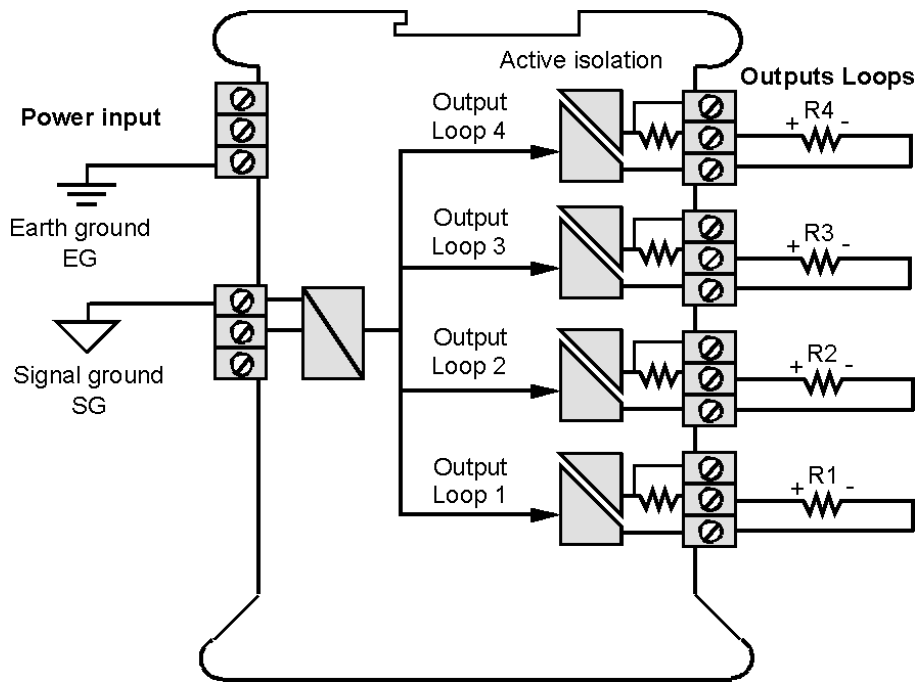

**Floating loads:** Any output load  $R$  that is floating (not connected to a local ground or earth ground) can be connected between current output (Pin 1) and current return (Pin 2). Current return is internally tied to signal ground  $SG$ , which can be floating or be connected to earth ground.

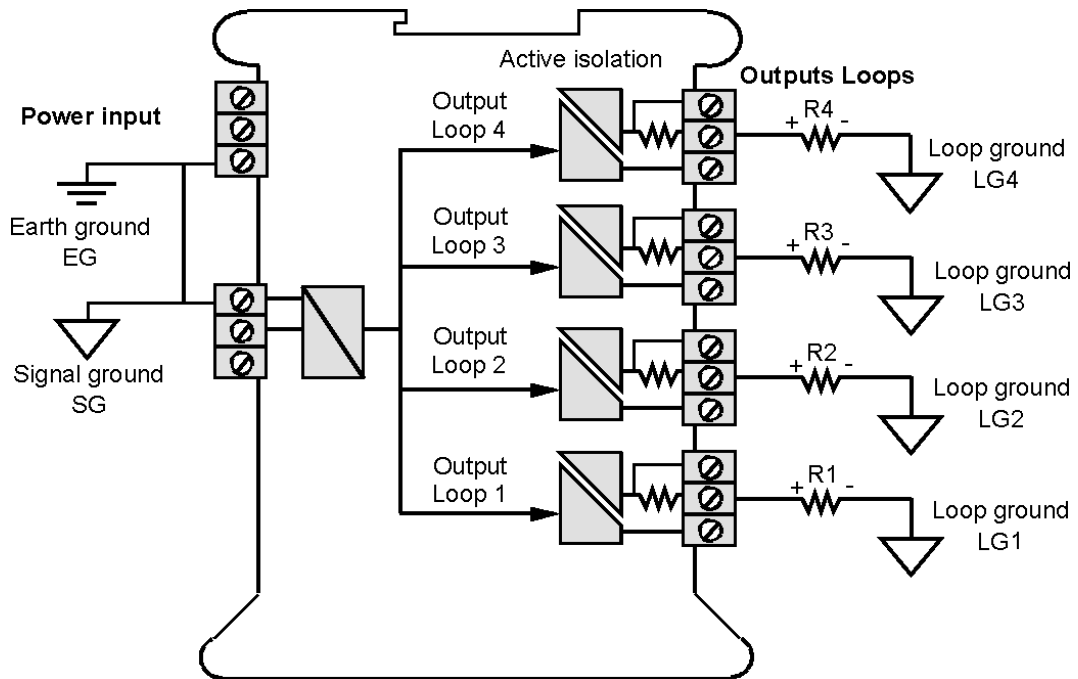

**Grounded loads:** Any output load  $R$  can be connected to a local loop ground  $LG$  instead of current return. The loop grounds  $LG$  can each be different, but can only differ from signal ground  $SG$  by a common mode voltage  $CMV$ , which is defined as  $V_{LG} - V_{SG}$ . Signal ground  $SG$  must be tied to earth ground  $EG$  or be within 1 Volt of  $EG$ .

If a load R is grounded to a local loop ground LG, the available common mode voltage CMV is limited on the positive side by the unit's internal power supply and on the negative side by the 600 mW power dissipation limit of an output transistor. The diagram to the right shows allowable CMV as a function of output load resistance R. For example, with a 250 ohm load, CMV can range from -13V to +17V. With a 500 ohm load, CMV can range from -18V to +12V. The unit will not work correctly if CMV limits are exceeded or load resistance is greater than 600 ohms.

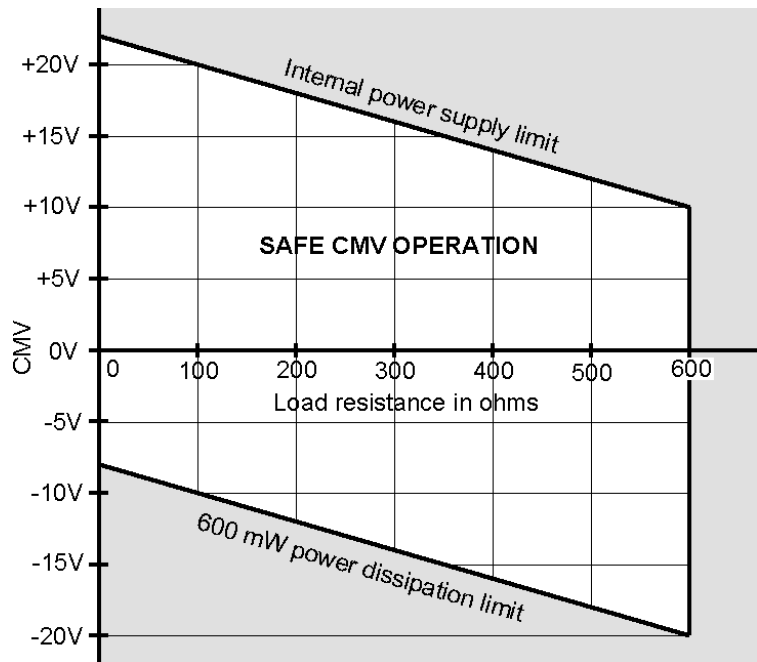

## 8. SETTING & CALIBRATION

Zero and span of the four output loops (**L1**, **L2**, **L3**, **L4**) are set by means of precision 25-turn potentiometers marked **Z** (for zero) and **S** (for span) on the front panel. The unit is factory jumpered and calibrated so that 4-20 mA in produces 4-20 mA out on all output channels.

To set or calibrate an output channel, apply the low input signal (4 mA, 0V or 1V) which should produce the 4 mA low output. Measure the actual output (e.g., 4.218 mA). Then apply the high input signal (20 mA, 5V or 10V) which should produce the 20 mA high output. Adjust the **S** potentiometer until actual output current equals the just-measured low output plus 16 mA (e.g., 4.218 mA + 16 mA = 20.218 mA). Then reapply the low input which should produce a 4 mA output, and adjust the **Z** potentiometer until the actual output current equals 4.000 mA.

Since electronic components may change as they age, annual recalibration of the output channels is recommended using the **Z** and **S** potentiometers. The input channel does not require calibration.

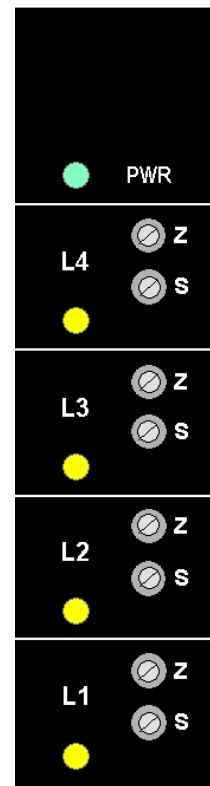

## 9. SPECIFICATIONS

### Mechanical

Mounting .....	35 mm DIN rail per EN50 022
Dimensions.....	22.5 x 103 x 128 mm (0.9" x 4.1" x 5.0") W x H x D
Weight .....	140 g (5 oz)
Connectors .....	Detachable plug-in screw-clamp connectors
Wire Size.....	28-12 AWG, 2.5 sq. mm max

### Signal Input

Signal Type .....	4-20 mA, 1-5V, 0-5V, 0-10V (jumper selectable)
Input Resistance .....	50 $\Omega$ for 4-20 mA, 500 k $\Omega$ for 1-5V & 0-5V, 1 M $\Omega$ for 0-10V
Transmitter Excitation.....	24 Vdc nominal, 30 mA max

### Signal Outputs

Number of Outputs .....	4
Signal Type .....	4-20 mA
Zero & Span Adjustment.....	$\pm 10\%$ for each output with 25-turn potentiometers
Signal Isolation .....	Please see graph on page 6
Voltage Compliance .....	12V (600 $\Omega$ per loop at 20 mA)
Load Regulation.....	$\pm 0.005\%$ of span from 0 to 600 $\Omega$
Accuracy .....	$\pm 0.02\%$ max span error at 23 $^{\circ}$ C
Span Tempco.....	$\pm 10$ ppm/ $^{\circ}$ C (0.16 $\mu$ A/ $^{\circ}$ C) typical, $\pm 25$ ppm/ $^{\circ}$ C (0.4 $\mu$ A/ $^{\circ}$ C) max
AC Rejection .....	90 dB from DC to 60 Hz
Response Speed .....	2 ms risetime, 7 ms settling time to 0.1% of final value
Current Test Point.....	10 $\Omega$ $\pm 0.5\%$ series resistor drops 200 mV at 20 mA
Loop Continuity Indication .....	Yellow LED lamp per loop, brightness increases with current

### Power Input

Standard Power (QLS-1) .....	85-264 Vac or 90-300 Vdc (DC operation not UL approved)
Low Power Option (QLS-2) .....	10-48 Vdc or 12-32 Vac
Power Frequency .....	DC or 47-63 Hz
Power Isolation.....	250V rms working, 2.3 kV rms per 1 min test
Power Consumption .....	3.5 W max, all loops delivering 20 mA
Power On Indication .....	Green LED lamp

### Environmental

Operating Temperature .....	-40 $^{\circ}$ C to 70 $^{\circ}$ C
Storage Temperature .....	-40 $^{\circ}$ C to 85 $^{\circ}$ C
Relative Humidity.....	95% at 40 $^{\circ}$ C, non-condensing
Cooling Required .....	Mount units with ventilation holes at top and bottom. Leave 6 mm (1/4") between units, or force air with a fan.

## **10. WARRANTY**

Laurel Electronics Inc. warrants its products against defects in materials or workmanship for a period of one year from the date of purchase.

In the event of a defect during the warranty period, the defective unit may be returned to the seller, which may be Laurel or a Laurel distributor. The seller may then repair or replace the defective unit at its option. In the event of such a return, freight charges from the buyer shall be paid by the buyer, and freight charges from the seller shall be paid by the seller.

### **LIMITATION OF WARRANTY**

The foregoing warranty shall not apply to defects resulting from:

1. Improper installation or miswiring.
2. Improper or inadequate maintenance.
3. Unauthorized modification or misuse.
4. Operation outside the environmental specifications.
5. Mishandling or abuse.

The warranty set forth above is exclusive and no other warranty, whether written or oral, is expressed or implied. Laurel specifically disclaims implied warranties of merchantability and fitness for a particular purpose.

Any electronic product may fail or malfunction over time. To minimize risks associated with reliance on Laurel products, users are expected to provide adequate system-level design and operating safeguards. Laurel's products are intended for general purpose industrial or laboratory use. They are not intended nor certified for use in life-critical medical, nuclear, or aerospace applications, or for use in hazardous locations.

### **EXCLUSIVE REMEDIES**

The remedies provided herein are Buyer's sole and exclusive remedies. In no event shall Laurel be liable for direct, indirect, incidental or consequential damages (including loss of profits) whether based on contract, tort, or any other legal theory.